

NOTICE DE MONTAGE

MONTAGE

- * Repérer les 4 trous existants "X" dans la traverse arrière.
- * Insérer l'attelage dans la traverse aux points "X" à l'aide de l'ensemble visserie "X".

FINITION

- * Serrer l'ensemble aux couples indiqués ci-dessous.
- * Monter la tête d'attelage et le support prise aux points "Y".

BLOC VISSERIE

X
100Nm

	4 vis HM12x110
	4 écrous HM12
	4 rondelles plates 12,5/30
	4 rondelles DEC12

Z
170Nm

	2 vis HM16x45
	2 écrous HM16
	2 rondelles DEC16

Y
100Nm

	2 vis HM12x60
	2 écrous HM12
	2 rondelles DEC12
	1 rondelle plate 12,5/27

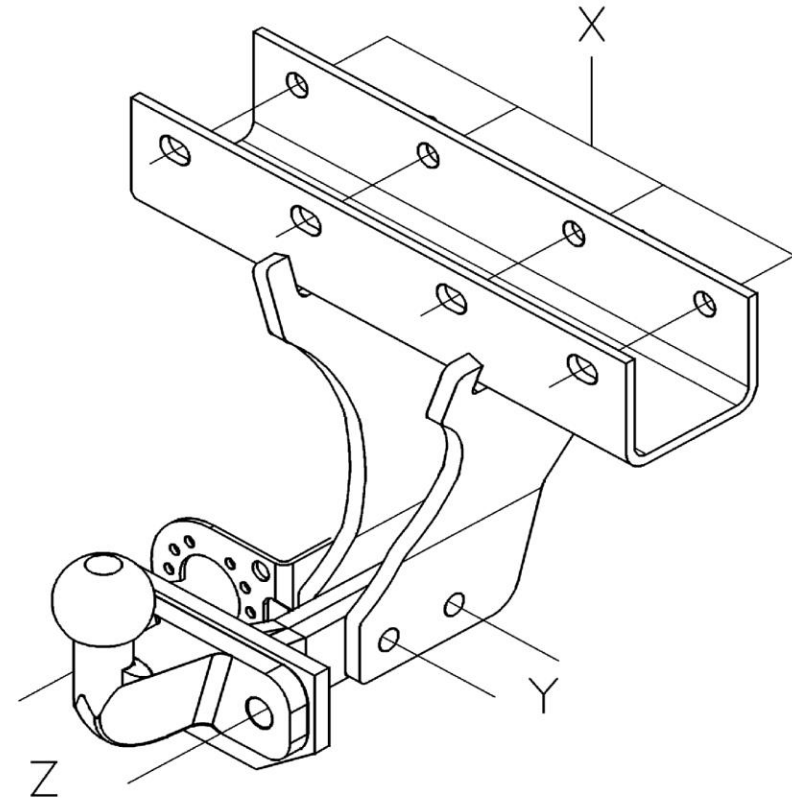

Type SI056	Homologation de Type n°	Poids Total maxi autorisé	Poids Total remorquable	Charge verti- cale maxi	Valeur D
Attelage pour Chrysler Jeep Wrangler (Std) Jeep unlimited overland (Std)	e24*94/20*0083*02	2 730 kg	3 500 kg	170 kg	15,04 kN

NOTA : Schéma électrique à l'intérieur de nos faisceaux universels ou personnalisés.



NE PAS UTILISER DE BOULONNEUSE



ATTENTION : (pour connaître les caractéristiques d'utilisation consulter la carte grise)

Installé suivant nos recommandations, cet attelage vous donnera entière satisfaction.
Nous dégageons toute responsabilité en cas de transformation ou d'utilisation illicite de celui-ci.

ASSEMBLY INSTRUCTIONS

ASSEMBLY

- * Mark the 4 existing holes "X" in the rear cross-member.
- * Insert the coupling in the cross-member at point "X" using bolting kit "X".

FINISHING

- * Tighten all of the nuts, bolts and screws to the torques indicated below.
- * Fit the coupling head and socket support at point "Y".

FASTENING KIT

X
100Nm | 4 HM12x110 screws
 | 4 HM12 nuts
 | 4 12,5/30 plain washers
 | 4 washers DEC12

Z
170Nm | 2 HM16x45 screws
 | 2 HM16 nuts
 | 2 DEC16 washers

Y
100Nm | 2 HM12x60 screws
 | 2 HM12 nuts
 | 2 DEC12 washers
 | 1 12,5/27 plain washer

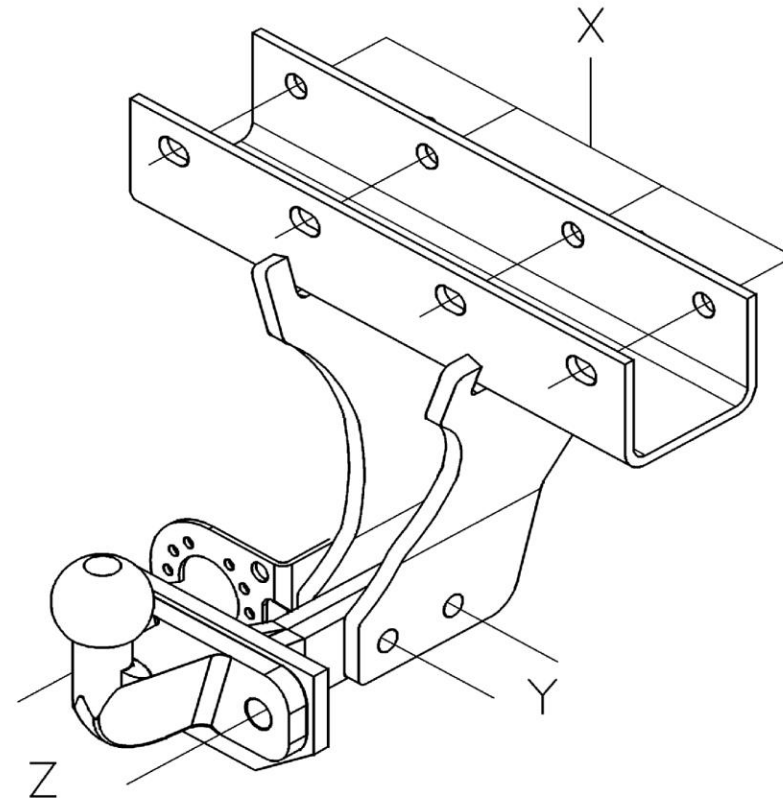

Type SI056	Type Approval No.	Max. Total Authori. Weight	Max. Total Towable Weight	Max. Verti- cal load	Value D
Tow bar for Chrysler Jeep Wrangler (Std) Jeep unlimited overland (Std)	e24*94/20*0083*02	2 730 kg	3 500 kg	170 kg	15,04 kN

NB : Electrical diagram inside our universal or custom wiring kits.



DON'T USE IMPACT WRENCH



PLEASE NOTE : (to familiarise yourself with the operating characteristics refer to the log)

If this tow bar is fitted in accordance with our recommendations it will give a completely satisfaction. We cannot accept any responsibility in the event of changes to or improper use of this item.

MONTÁŽNÍ POSTUP

MONTÁŽ

- * V zadní příčce najdete 4 existující otvory „X“.
- * Pomocí sady šroubů „X“ vsuňte tažné zařízení do příčky, do bodů „X“.

DOKONČOVACÍ PRÁCE

- * Utáhněte všechny šrouby na níže uvedené utahovací momenty.
- * Namontujte hlavici závěsu pro přívěs a držák zásuvky do bodů „Y“.

SADY ŠROUBŮ

X
100Nm

4 šrouby HM12x110
4 šroubů HM12
4 ploché podložky 12,5/30
4 podložky DEC12

Z
170Nm

2 šrouby HM16x45
2 šroubů HM16
2 podložky DEC16

Y
100Nm

2 šrouby HM12x60
2 šroubů HM12
2 podložky DEC12
1 ploché podložky 12,5/27

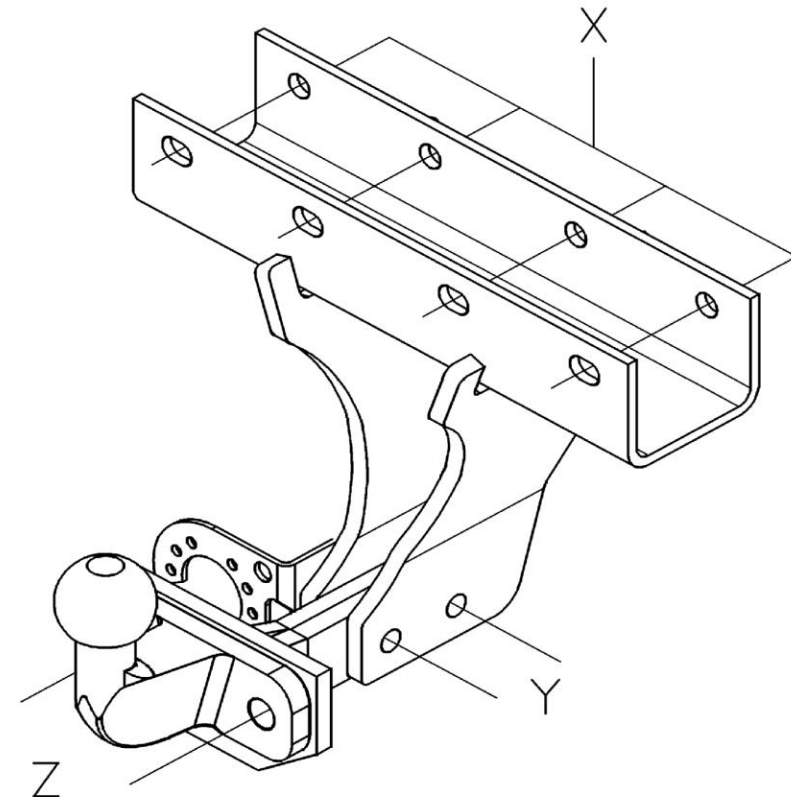

Typ SI056	Homologace Typu č.	Celková maximální povolená váha	Celková tažná hmotnost	Maximální ver- tikální zatížení	Hodnota D
Tažné zařízení pro Chrysler Jeep Wrangler (Std) Jeep unlimited overland (Std)	e24*94/20*0083*02	2 730 kg	3 500 kg	170 kg	15,04 kN

POZNÁMKA: Elektrické schéma univerzálních nebo na míru upravených svazků.



NEPOUŽÍVEJTE ŠROBOVACÍ STROJ



POZOR: (uživatelské charakteristiky naleznete v technickém průkazu)

Tažné zařízení instalované dle našich doporučení vás plně uspokojí.

V případě přestavby nebo neoprávněného užívání se zbavujeme veškeré odpovědnosti

MONTERING

- * Afmærk de 4 eksisterende huller "X" i bagtraversen.
- * Indfør anhængertrækket i traversen ved punkterne "X" med befæstelserne "X".

TIL SLUT

- * Tilspænd befæstelserne med nedennævnte momenter.
- * Monter kuglehovedet og holderen til stikket ved punkterne "Y".

BEFÆSTELSER

X
100Nm

	4 bolte HM12x110
	4 møtrikker HM12
	4 flade skiver 12,5/30
	4 skiver DEC12

Z
170Nm

	2 bolte HM16x45
	2 møtrikker HM16
	2 skiver DEC16

Y
100Nm

	2 bolte HM12x60
	2 møtrikker HM12
	2 skiver DEC12
	1 flade skiver 12,5/27

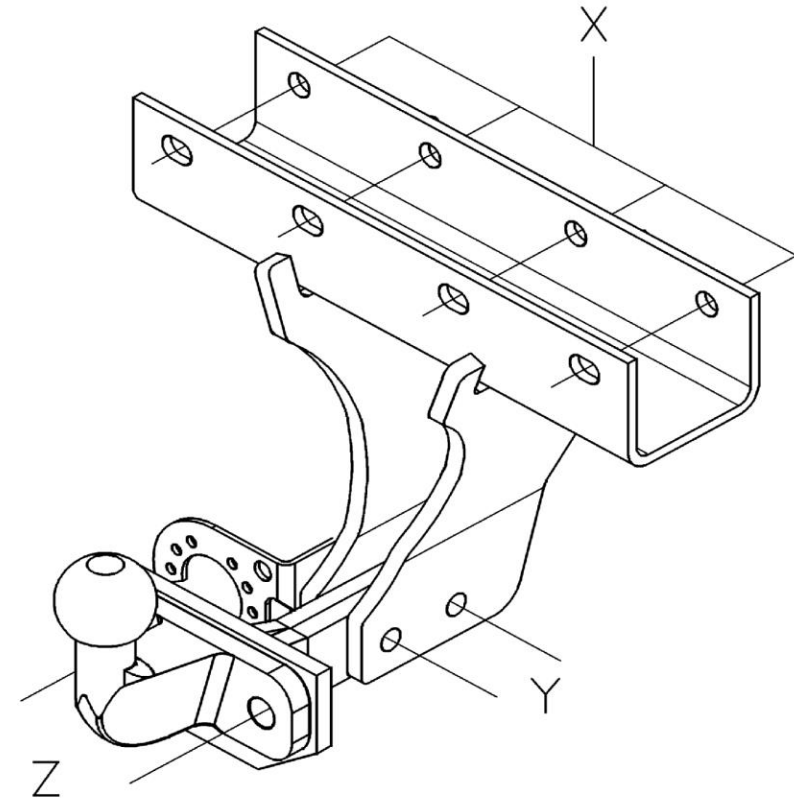

Type	Godkendt typenr.	Totalvægt maks. tilladt	Totalvægt anhängervægt	Kugletryk maks.	Værdi D
SI056					
Anhængertræk til Chrysler Jeep Wrangler (Std) Jeep unlimited overland (Std)	e24*94/20*0083*02	2 730 kg	3 500 kg	170 kg	15,04 kN

NB: El-skema for vores universelle eller specielle ledningsnet.



BRUG IKKE EN BOLTNINGSMASKINE



BEMÆRK: (for yderligere oplysninger om anvendelsesforhold henvises der til registreringsattesten)

Hvis dette anhængertræk monteres i henhold til vores anvisninger, vil det være til din fulde tilfredshed. Vi fralægger os ethvert ansvar ved ulovlig ændring eller brug af anhængertrækket.

MONTAGE

- * Kennzeichnen Sie die 4 Löcher « X » auf dem hinteren Querträger.
- * Führen Sie die Kupplung mithilfe der Verschraubung « X » an den Punkten « X » ein.

FERTIGSTELLUNG

- * Ziehen Sie die gesamte Verschraubung mit den unten angegebenen Drehmomenten an.
- * Montieren Sie den Kupplungskopf und die Steckerhalterung mithilfe der Verschraubung an den Punkten « Y ».

SCHRAUBENSATZ

X
100Nm | 4 Schrauben HM12x110
 | 4 Muttern HM12
 | 4 flache Scheiben 12,5/30
 | 4 Scheiben DEC12

Z
170Nm | 2 Schrauben HM16x45
 | 2 Muttern HM16
 | 2 Scheiben DEC16

Y
100Nm | 2 Schrauben HM12x60
 | 2 Muttern HM12
 | 2 Scheiben DEC12
 | 1 flache Scheiben 12,5/27

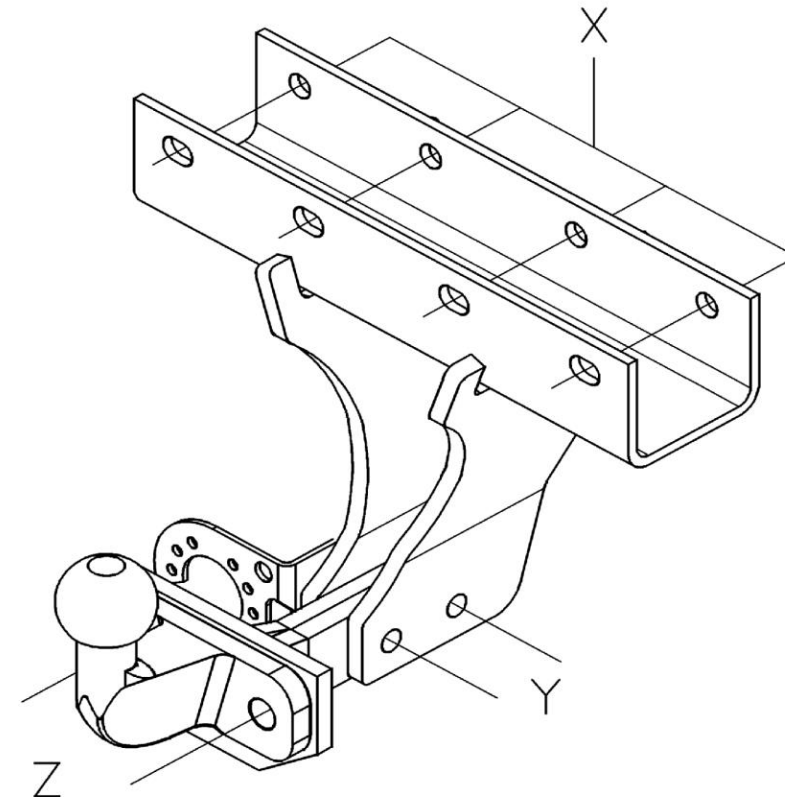

Typ SI056	EG Genehmigungs-Nr.	Maximal zulässiges Gesamtgewicht	Maximal zulässiges Anhängelast	Maximale Stützlast	Max. D-Wert
Anhängevorrichtung Chrysler Jeep Wrangler (Std) Jeep unlimited overland (Std)	e24*94/20*0083*02	2 730 kg	3 500 kg	170 kg	15,04 kN

HINWEIS: Elektroschema liegt unseren (Universal - oder spezifische) Kabelsätzen bei.



KEINEN SCHRAUBER VERWENDEN



ACHTUNG: (Nutzungsmerkmale : siehe Fahrzeugschein)

Diese Anhängevorrichtung wird Sie voll zufrieden stellen, wenn Sie unsere Montageanleitung befolgen.

Im Falle der unerlaubten Veränderung oder des unerlaubten Gebrauchs lehnen wir jede Haftung ab.

ΣΗΜΕΙΩΣΗ ΤΟΠΟΘΕΤΗΣΗΣ

ΤΟΠΟΘΕΤΗΣΗ

- * Εντοπίστε τις 4 οπές « X » που υπάρχουν στην πίσω τραβέρσα .
- * Εισαγάγετε το σύστημα ρυμούλκησης στην τραβέρσα στα σημεία « X » με τη βοήθεια του συνόλου των κοχλιών « X ».

ΤΕΛΕΙΩΜΑ

- * Σφίξτε όλες τις βίδες με τις ροπές στρέψης που αναφέρονται παρακάτω.
- * Τοποθετήστε την κεφαλή του συστήματος ρυμούλκησης και τη βάση πρίζας στα σημεία « Y ».

ΣΥΝΟΛΑ ΚΟΧΛΙΩΝ

X
100Nm

4 βίδες HM12x110
4 περικόχλια HM12
4 ροδέλες πλακέ 12,5/30
4 ροδέλε DEC12

Z
170Nm

2 βίδες HM16x45
2 περικόχλια HM16
2 ροδέλε DEC16

Y
100Nm

2 βίδες HM12x60
2 περικόχλια HM12
2 ροδέλε DEC12
1 ροδέλες πλακέ 12,5/27

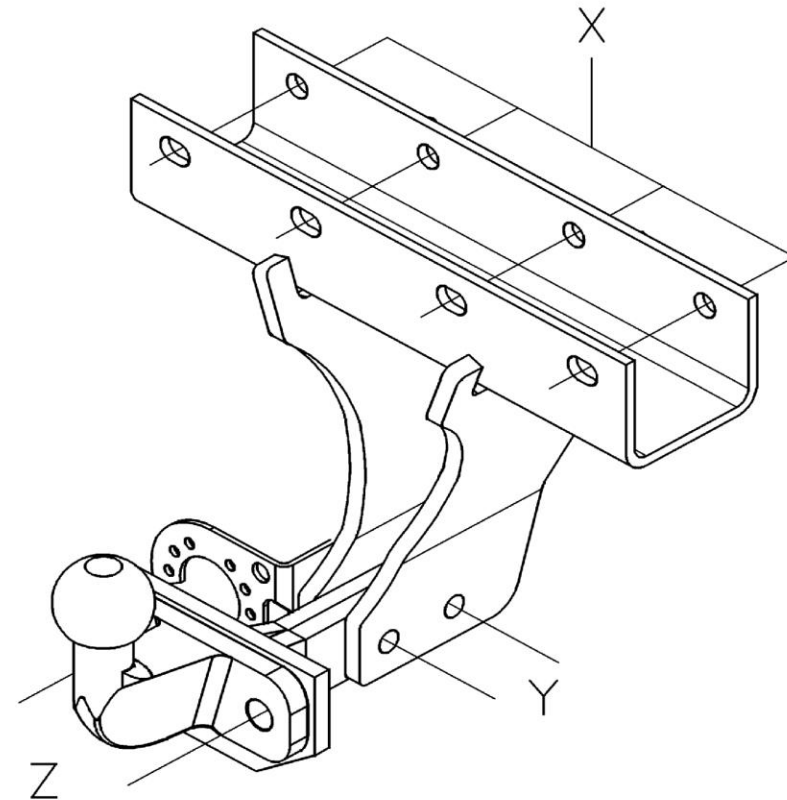

Τύπος SI049	Εγκριση Τύπου αριθ.	Ολικό Βάρος μέγ Επιτρεπόμενο	Ολικό Βάρος ρυμουλκήσιμο	Κατακόρυφο φορτίομέγ.	Τιμή D
Σύστημα ρυμούλκησης για Chrysler Jeep Wrangler (Std) Jeep unlimited overland (Std)	e24*94/20*0083*02	2 730 kg	3 500 kg	170 kg	15,04 kN

ΣΗΜΕΙΩΣΗ : Ηλεκτρικό κύκλωμα στο εσωτερικό των γενικής χρήσεως δεσμών μας ή προσωποποιημένων.



ΜΗΝ ΧΡΗΣΙΜΟΠΟΙΕΙΤΕ ΜΗΧΑΝΗ ΒΙΩΜΑΤΟΣ



ΠΡΟΣΟΧΗ : (για να πληροφορηθείτε τα χαρακτηριστικά χρήσης συμβουλευτείτε την γκριζα κάρτα)

Εγκατεστημένο σύμφωνα με τις συστάσεις μας, αυτό το σύστημα ρυμούλκησης θα σας ικανοποιήσει πλήρως.

Απεκδυόμεθα πάσης ευθύνης σε περίπτωση μετατροπής ή παράνομης χρήσης αυτού.

MONTAJE

- * Localizar los 4 orificios existentes “X” en la traviesa trasera.
- * Introducir el ensamblaje en la traviesa, en los puntos “X” con la ayuda del conjunto de tornillos y pernos “X”.

ACABADO

- * Apretar el conjunto de tornillos y pernos a las parejas indicadas a continuación.
- * Montar la cabeza de ensamblaje y el soporte de la toma en los puntos “Y”.

BLOQUE TORNILLERÍA

X
100Nm

- 4 tornillos HM12x110
- 4 tuercas HM12
- 4 arandelas planas 12,5/30
- 4 arandelas DEC12

Z
170Nm

- 2 tornillos HM16x45
- 2 tuercas HM16
- 2 arandelas DEC16

Y
100Nm

- 2 tornillos HM12x60
- 2 tuercas HM12
- 2 arandelas DEC12
- 1 arandela plana 12,5/27

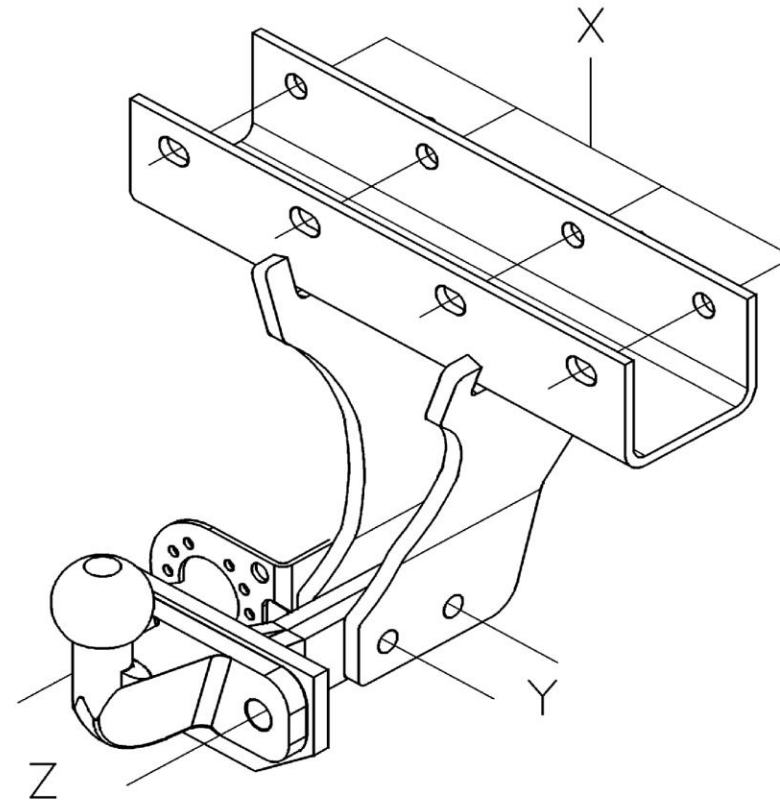

Tipo SI056	Homologación de Tipo n°	Peso Total má- ximo autorizado	Peso Total remolcable	Carga verti- cal máxima	Valor D
Enganche para Chrysler Jeep Wrangler (Estándar) Jeep unlimited overland (Estándar)	e24*94/20*0083*02	2 730 kg	3 500 kg	170 kg	15,04 kN

NOTA: Esquema eléctrico en el interior de nuestros haces universales o personalizados.



NO UTILICE UNA MÁQUINA DE ATORNILLAR



ATENCIÓN: (para conocer las características de utilización, consultar el permiso de circulación)

Instalado siguiendo nuestras recomendaciones, este enganche le dará total satisfacción.
 No asumiremos ninguna responsabilidad en caso de que haya sido transformado
 o utilizado ilícitamente

ASENNUSOHJEET

ASENNUS

- * Etsi 4 valmista reikää « X » takapoikittaispalkissa.
- * Laita vetokoukku poikittaispalkkiin pisteissä « X » ruuvien « X » avulla.

VIIMEISTELY

- * Kiristä ruuvit alla ilmoitetuilla momenteilla.
- * Kiinnitä vetokoukun pää ja pistorasian tuki pisteisiin « Y ».

KIINNITYSKOKONAISUUS

X
100Nm | 4 ruuvia HM12x110
 | 4 mutteria HM12
 | 4 litteää välilevyä 12,5/30
 | 4 välilevyä DEC12

Z
170Nm | 2 ruuvia HM16x45
 | 2 mutteria HM16
 | 2 välilevyä DEC16

Y
100Nm | 2 ruuvia HM12x60
 | 2 mutteria HM12
 | 2 välilevyä DEC12
 | 1 litteää välilevyä 12,5/27

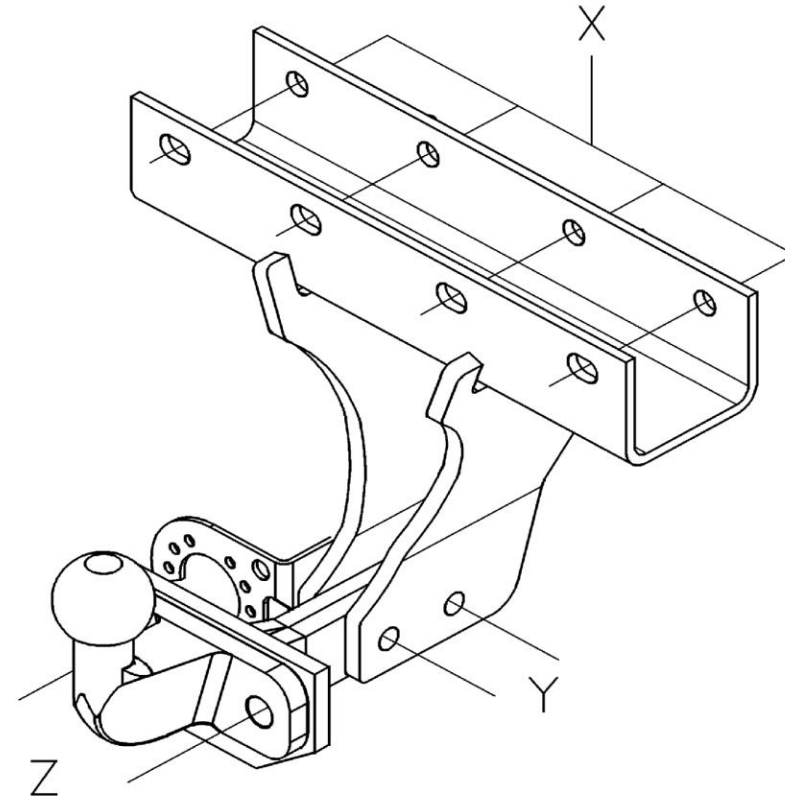

Tyyppi SI056	Tyyppihyväksyntä Numero	Suuri sallittu kokonaiskuorma	Vedettävissä oleva kokonaispaino	Suurin sallittu pystysuora rasitus	Arvo D
Vetokoukku Chrysler Jeep Wrangler (Vakio) Jeep unlimited overland (Vakio)	e24*94/20*0083*02	2 730 kg	3 500 kg	170 kg	15,04 kN

HUOM: Sähköpiirros on yleisjohtojen tai yksilöllisten johtojen mukana.



ÄLÄ KÄYTÄ PULTTAUSKONETTA



HUOMIO: (käyttöominaisuuksiin tutustumiseksi on katsottava rekistreriotetta)

Suosittelusten mukaan asennettuna tämä vetokoukku täyttää odotuksesi.
 Emme ota vastuuta, jos laitetta muutetaan tai käytetään ohjeiden vastaisesti.

AVVERTENZE PER IL MONTAGGIO

MONTAGGIO

- * Individuare i 4 fori esistenti « X » sulla traversa posteriore.
- * Inserire il gancio di traino sulla traversa nei punti « X » per mezzo del gruppo viteria « X ».

RIFINITURA

- * Stringere il gruppo viteria alle coppie qui di seguito indicate.
- * Montare la testa del gancio di traino e il supporto presa nei punti « Y ».

BLOCCO VITERIA

X
100Nm | 4 viti HM12x110
 | 4 dadi HM12
 | 4 rondelle piatte 12,5/30
 | 4 rondelle DEC12

Z
170Nm | 2 viti HM16x45
 | 2 dadi HM16
 | 2 rondelle DEC16

Y
100Nm | 2 viti HM12x60
 | 2 dadi HM12
 | 2 rondelle DEC12
 | 1 rondelle piatte 12,5/27

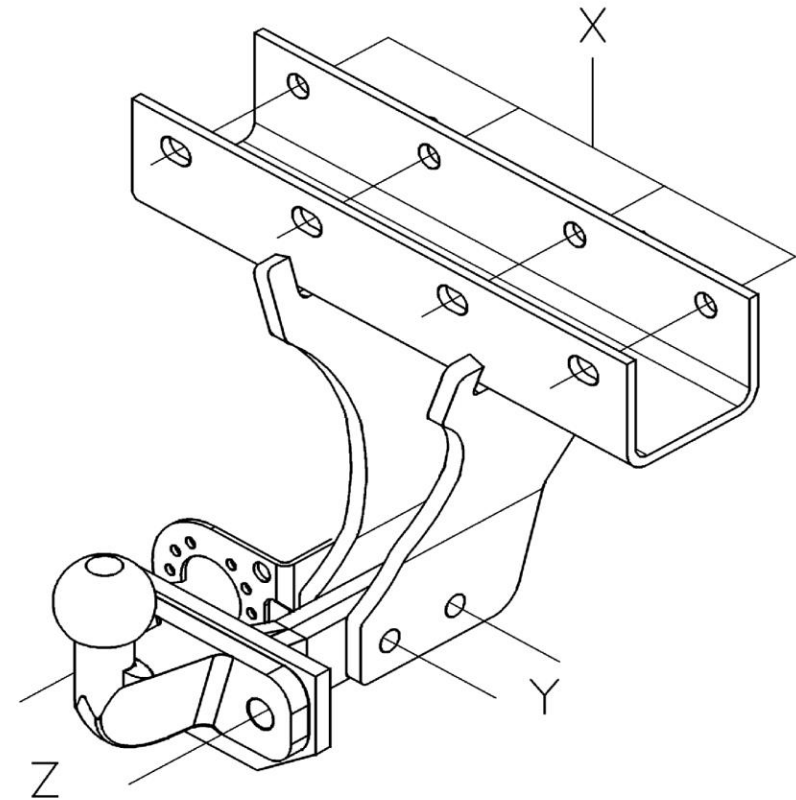

Tipo SI056	Omologazione di Tipo n°	Peso totale massimo autorizzato	Peso totale Rimorchiabile	Carico verticale massimo	Valore D
Gancio da traino per Chrysler Jeep Wrangler (Std) Jeep unlimited overland (Std)	e24*94/20*0083*02	2 730 kg	3 500 kg	170 kg	15,04 kN

NOTA : Schema elettrico all'interno dei nostri fasci universali o personalizzati.



NON USARE UNA MACCHINA PER IMBULLONARE



ATTENZIONE : (per conoscere le caratteristiche d'uso consultare il libretto di circolazione)

Installato seguendo le nostre raccomandazioni, questo gancio da traino vi lascerà completamente soddisfatti.

Respingiamo ogni responsabilità in caso di trasformazione o utilizzo illecito dello stesso.

MONTAGEHANDLEIDING

MONTAGE

- * Markeer de 4 bestaande openingen in de achterdwarsbalk met « X ».
- * Voeg de koppeling in de dwarsbalk in aan de punten « X » met behulp van het schroefwerk « X ».

AFWERKING

- * Zet het geheel van het schroefwerk vast op de hieronder aangegeven koppels.
- * Monteer de koppelingskop en de contactdrager aan de punten « Y ».

SCHROEFBLOK

X
100Nm | 4 schroeven HM12x110
4 moeren HM12
4 drukplaten 12,5/30
4 ringen DEC12

Z
170Nm | 2 schroeven HM16x45
2 moeren HM16
2 ringen DEC16

Y
100Nm | 2 schroeven HM12x60
2 moeren HM12
2 ringen DEC12
1 drukplaten 12,5/27

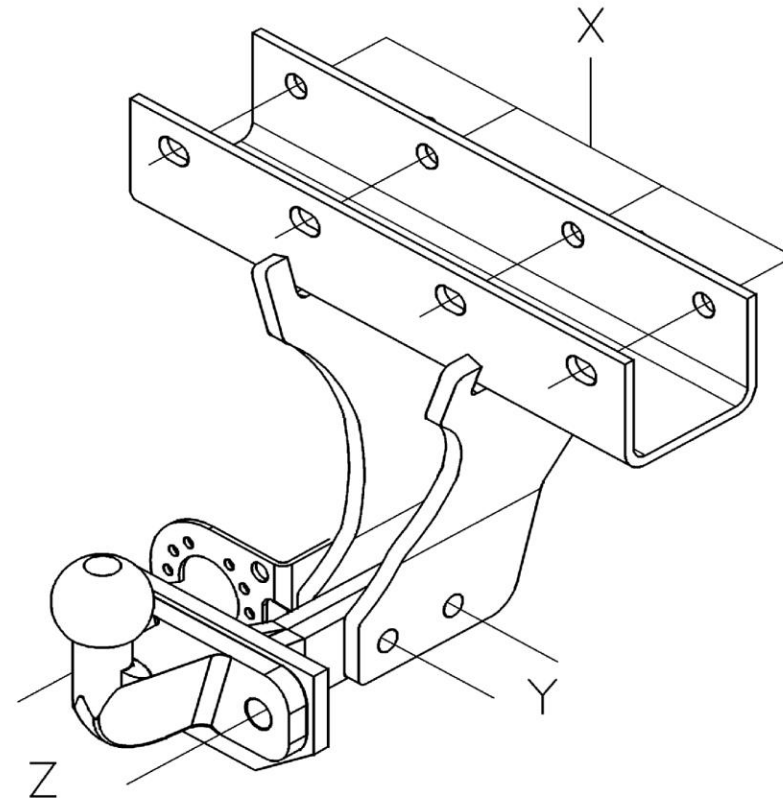

Type SI056	Goedkeuring Type n°	Max. toegestaan totaalgewicht	Totaal laadgewicht	Max. verticale belasting	Waarde D
Koppeling voor Chrysler Jeep Wrangler (Std) Jeep unlimited overland (Std)	e24*94/20*0083*02	2 730 kg	3 500 kg	170 kg	15,04 kN

NOTA BENE: Bedradingsschema aan binnenkant van onze universele bundels of gepersonaliseerd.



GEBRUIK GEEN BOUTMACHINE



LET OP: (voor gebruikskennmerken het kentekenbewijs raadplegen)

Indien u de koppeling volgens onze aanbevelingen heeft geïnstalleerd, zal het u tot volle tevredenheid stemmen. Wij stellen ons niet aansprakelijk in geval van wijziging of onrechtmatig gebruik.

MONTERING

- * Merk av de 4 eksisterende hullene "X" i den bakre tverrbjelken.
- * Sett hengerfestet inn i tverrbjelken i punktene "X" ved hjelp av skruesettet "X".

ENDELIG UTFØRING

- * Skru til alle skruene ved punktene som vist nedenfor.
- * Monter kroken for hengerfestet og holderen for kontakten i punktene "Y".

SKRUESETT

X
100Nm | 4 skruer HM12x110
 | 4 muttere HM12
 | 4 tetningsskiver 12,5/30
 | 4 skiver DEC12

Z
170Nm | 2 skruer HM16x45
 | 2 muttere HM16
 | 2 skiver DEC16

Y
100Nm | 2 skruer HM12x60
 | 2 muttere HM12
 | 2 skiver DEC12
 | 1 tetningsskiver 12,5/27

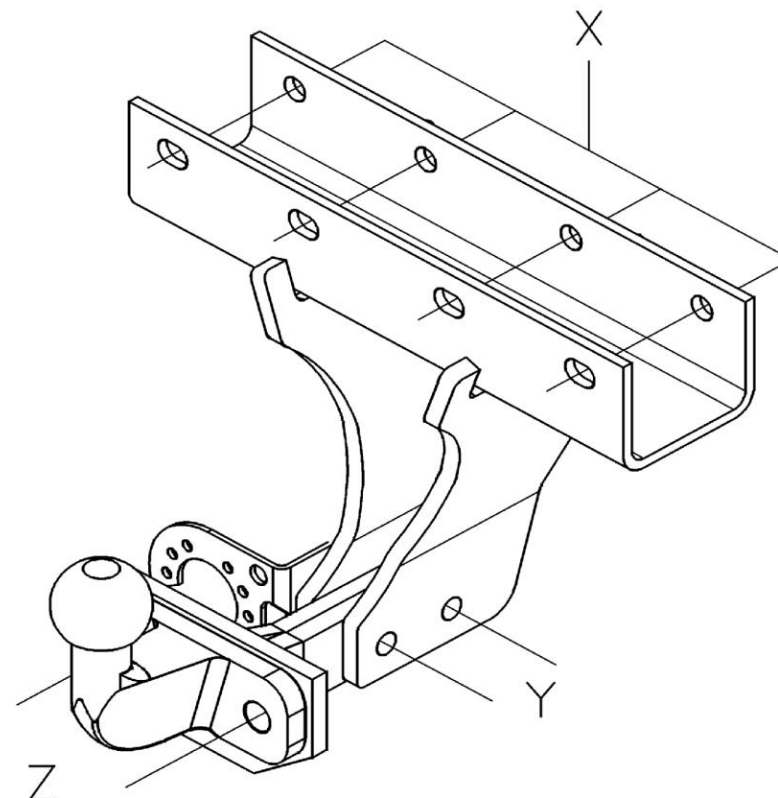

Type	Homologering type nr.	Total vekt maks. godkjent	Total vekt mulig med tilhenger	Totalvekt tilhenger maks. avstand	Verdi D
SI056					
Tilhengerfeste til Chrysler Jeep Wrangler (Std) Jeep unlimited overland (Std)	e24*94/20*0083*02	2 730 kg	3 500 kg	170 kg	15,04 kN

MERKNAD: Elektrisk skjema finnes i våre generelle eller personliggjorte brosjyrer.



IKKE BRUK BOULONNEUSEN



ADVARSEL: (for kunnskap om bruksegenskapene, se vognkortet)

Ved å installere innretningen i samsvar med våre anbefalinger vil du få maksimalt utbytte av dette tilhengerfestet.

Vi fraskriver oss alt ansvar hvis tilhengerfestet endres eller brukes på ulovlig måte.

INSTRUKCJA MONTAŻU

MONTAŻ

- * Odszukać 4 istniejące otwory „X” w tylnej poprzecznej listwie.
- * Wsunąć dyszel w poprzeczną listwę w punktach « X », za pomocą zestawu śrub « X ».

WYKOŃCZENIE

- * Dokręcić wszystkie śruby zgodnie z momentami dokręcenia oznaczonymi poniżej.
- * Zamontować czoło dyszla i wspornik w punktach « Y ».

ZESTAW ŚRUB

X
100Nm

4 śruby HM12x110
4 nakładki HM12
4 płaskie podkładki okrągłe 12,5/30
4 okrągłych podkładkach DEC12

Z
170Nm

2 śruby HM16x45
2 nakładki HM16
2 okrągłych podkładkach DEC16

Y
100Nm

2 śruby HM12x60
2 nakładki HM12
2 okrągłych podkładkach DEC12
1 płaskie podkładki okrągłe 12,5/27

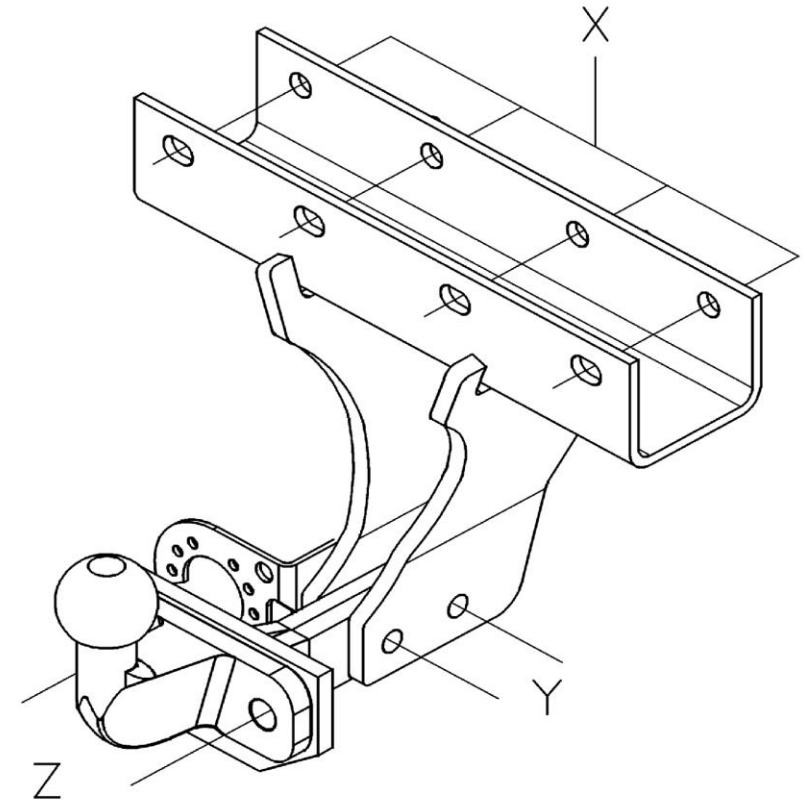

Typ SI056	Homologacja typu nr	Ciężar całkowity <small>holowania / dopuszczalny</small>	Ciężar całkowity <small>holowania / dopuszczalny</small>	Maksymalne obciążenie pionowe	Wartość D
Dyszel holowniczy do Chrysler Jeep Wrangler (Std) Jeep unlimited overland (Std)	e24*94/20*0083*02	2 730 kg	3 500 kg	170 kg	15,04 kN

Uwaga: schemat elektryczny dołączony do wiązki podłączeniowej uniwersalnej lub specjalnej



NIE UŻYWAĆ MASZINY DO SKRĘCANIA



UWAGA (charakterystyki użytkownika należy sprawdzić w dowodzie rejestracyjnym)

Dyszel holowniczy będzie funkcjonował we właściwy sposób po zainstalowaniu go zgodnie z zaleceniami. Nie ponosimy żadnej odpowiedzialności w przypadku wprowadzenia zmian lub niedozwolonego użycia

MONTERINGSANVISNING

MONTERING

- * Hitta de 4 befintliga hålen "X" på den bakre tvärbalken.
- * För in dragkroken i tvärbalken vid punkterna "X" med hjälp av skruvsatsen "X".

SLUTLIGEN

- * Skruva åt alla skruvar med nedanstående vridmoment.
- * Montera dragkrokens huvud och stödfästet vid punkterna "Y".

SKRUVBLOCK

X
100Nm | 4 skruvar HM12x110
 | 4 muttrar HM12
 | 4 rundbrickor 12,5/30
 | 4 fjäderbrickor DEC12

Y
100Nm | 2 skruvar HM12x60
 | 2 muttrar HM12
 | 2 fjäderbrickor DEC12
 | 1 rundbrickor 12,5/27

Z
170Nm | 2 skruvar HM16x45
 | 2 muttrar HM16
 | 2 fjäderbrickor DEC16

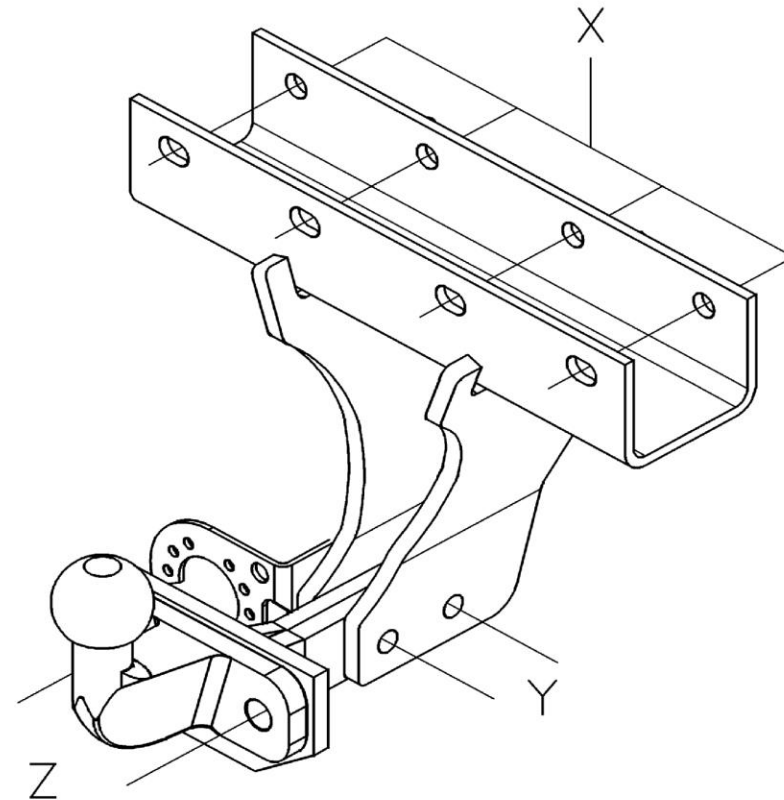

Typexemplar SI056	Typgodkännande Av typexemplar n°	Totalvikt Maxi-vikt	Totalvikt bogserbar	Vertikal maxi-vikt	Värde D
Montering av Chrysler Jeep Wrangler (Std) Jeep unlimited overland (Std)	e24*94/20*0083*02	2 730 kg	3 500 kg	170 kg	15,04 kN

Observera: Elektriskt schema finns i våra allmänna eller mer specialiserade anvisningar



ANVÄND INTE EN SKRUVMASKIN.



WARNING: (Läs igenom det grå bladet för att ta reda på rådande användningsvillkor)

Om du monterar produkten enligt våra anvisningar kommer du uppnå bästa möjliga resultat
 Vi avsäger oss allt ansvar i de fall kunden inte följt våra anvisningar fullt ut.

Dispositivo di traino tipo : **51 - 19**
Per autoveicolo : **Chrysler Jeep Wrangler (Standard)**
Tipo funzionale : **JK ?????? ??**



Classe e tipo di attacco : **A50-X**
Omologazione : **e24*94/20*0083*02**
Valore D : **15,04 kN**
Carico verticale max. S : **170 kg**
Massa rimorchiabile : vedi carta di circolazione dell'autoveicolo

In base alla Direttiva europea 94/20, la massa massima rimorchiabile del dispositivo di traino è determinata dal valore di prova "D" così definito :

$$D = (T \times C) / (T + C) \times 0,00981 = 10,22 \text{ kN}$$

dove : T = Massa complessiva max. della motrice (in kg) e C = Massa rimorchiabile max. della motrice (in kg)

DICHIARAZIONE DI CORRETTO MONTAGGIO :

la sottoscritta Ditta dichiara che il dispositivo di traino tipo _____ è stato installato a regola d'arte, nel rispetto dei punti d'attacco e delle prescrizioni fornite dalla Casa costruttrice

sul veicolo _____

targato _____

li _____

Si dichiara inoltre di aver informato l'utente del veicolo sull'USO e MANUTENZIONE del dispositivo stesso.

timbro et firma



holownicze.pl