

# 316 352 600 001 / 316 363 600 001

**ATTENTION : (pour connaître les caractéristiques d'utilisation consulter la carte grise).**

Installé suivant nos recommandations, cet attelage vous donnera entière satisfaction. Nous dégageons toute responsabilité en cas de transformation ou d'utilisation illicite de celui-ci

FR

**ACHTUNG: (Nutzungsmerkmale : siehe Fahrzeugschein)**

Diese Anhängervorrichtung wird Sie voll zufrieden stellen, wenn Sie unsere Montageanleitung befolgen. Im Falle der unerlaubten Veränderung oder des unerlaubten Gebrauchs lehnen wir jede Haftung ab.

DE

**PLEASE NOTE : (to familiarise yourself with the operating characteristics refer to the log).**

If this tow bar is fitted in accordance with our recommendations it will give a completely satisfaction. We cannot accept any responsibility in the event of changes to or improper use of this item.

EN

**BEMÆRK : (for yderligere oplysninger om anvendelsesforhold henvises der til registreringsattesten)**

Hvis dette anhængertræk monteres i henhold til vores anvisninger, vil det være til din fulde tilfredshed. Vi fralægger os ethvert ansvar ved ulovlig ændring eller brug af anhængertrækket.

DA

**ΠΡΟΣΟΧΗ : (για να πληροφορηθείτε τα χαρακτηριστικά χρήσης συμβουλευτείτε την γκριζα κάρτα)**

Εγκατεστημένο σύμφωνα με τις συστάσεις μας, αυτό το σύστημα ρυμούλκησης θα σας ικανοποιήσει πλήρως. Απεκδύομεθα πάσης ευθύνης σε περίπτωση μετατροπής ή παράνομης χρήσης αυτού.

EL

**ATENCIÓN: (para conocer las características de utilización, consultar el permiso de circulación)**

Instalado siguiendo nuestras recomendaciones, este enganche le dará total satisfacción. No asumiremos ninguna responsabilidad en caso de que haya sido transformado o utilizado ilícitamente.

ES

**UWAGA (charakterystyki użytkowania należy sprawdzić w dowodzie rejestracyjnym)**

Dyszel holowniczy będzie funkcjonował we właściwy sposób po zainstalowaniu go zgodnie z zaleceniami. Nie ponosimy żadnej odpowiedzialności w przypadku wprowadzenia zmian lub niedozwolonego użycia

PL

**HUOMIO: (käyttöominaisuuksiin tutustumiseksi on katsottava rekisteriotetta)**

Suosittelun mukaan asennettuna tämä vetokoukku täyttää odotuksesi.

Emme ota vastuuta, jos laitetta muutetaan tai käytetään ohjeiden vastaisesti.

FI

**ATTENZIONE : (per conoscere le caratteristiche d'uso consultare il libretto di ircolazione)**

Installato seguendo le nostre raccomandazioni, questo gancio da traino vi lascerà completamente soddisfatti. Respingiamo ogni responsabilità in caso di trasformazione o utilizzo illecito dello stesso.

IT

**LET OP : (voor gebruikkenmerken het kentekenbewijs raadplegen)**

Indien u de koppeling volgens onze aanbevelingen heeft geïnstalleerd, zal het u tot volle tevredenheid stemmen. Wij stellen ons niet aansprakelijk in geval van wijziging of onrechtmatig gebruik.

NL

**ADVARSEL: (for kunnskap om bruksegenskapene, se vognkortet)**

Ved å installere innretningen i samsvar med våre anbefalinger vil du få maksimalt utbytte av dette tilhengerfestet. Vi fraskriver oss alt ansvar hvis tilhengerfestet endres eller brukes på ulovlig måte.

NO

**POZOR: (užívateľské charakteristiky naleznete v technickém průkazu)**

Tažné zařízení instalované dle našich doporučení vás plně uspokojí. V případě přestavby nebo neoprávněného užívání se zbavujeme veškeré odpovědnosti

CZ

**VARNING: (Läs igenom registreringsbeviset för att ta reda på rådande användningsvillkor)**

Om du monterar produkten enligt våra anvisningar kommer du uppnå bästa möjliga resultat. Vi avsäger oss allt ansvar i de fall kunden inte följt våra anvisningar fullt ut.

SV

SCENIC 2

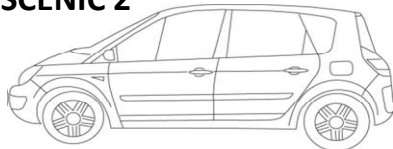

SCENIC 3

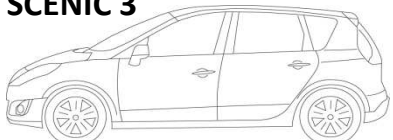

MEGANE 2

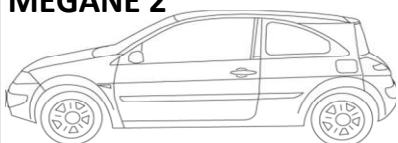

MEGANE 2

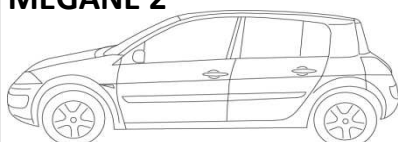

MEGANE 3

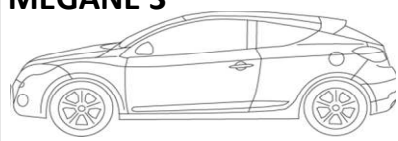

MEGANE 3

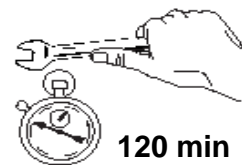
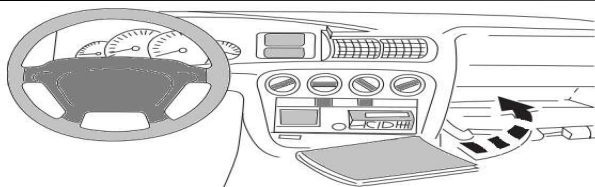
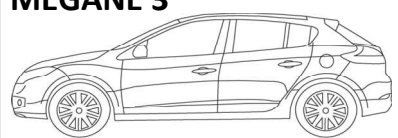

8,67 KN

SI 203

e24\*55R\*01 0321

SI 204

e24\*55R\*01 0322

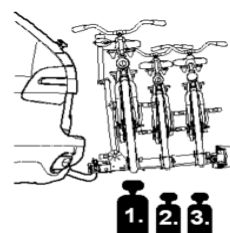

3 MAXI

60 Kg MAXI



30 Kg MAXI

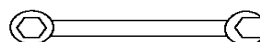
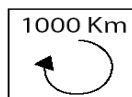
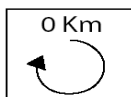

1500 Kg



75 kg

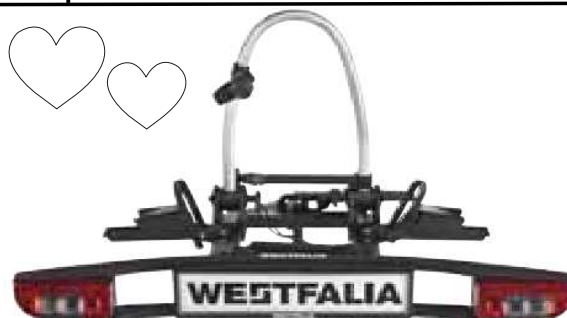

REF. WESTFALIA : 350030600001

REF. SIARR : 8570

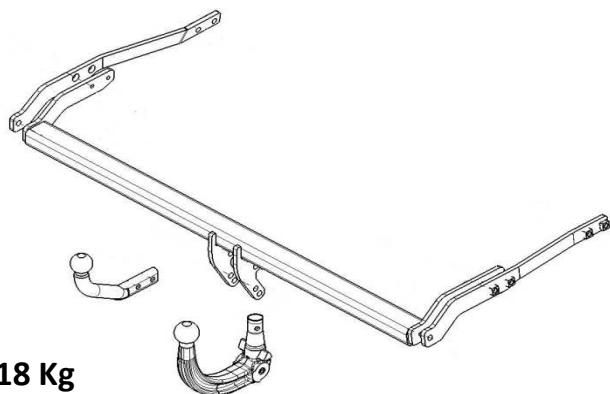

18 Kg



21 Kg



16 - 17 - 18 - 19





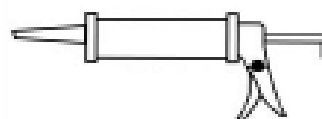
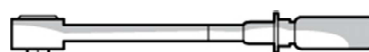

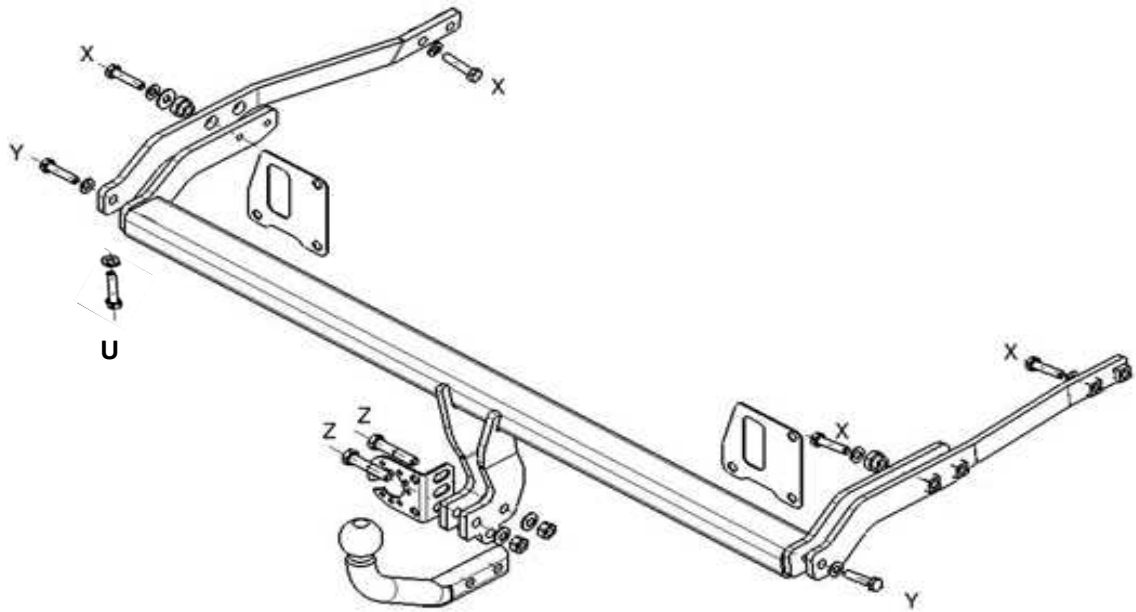

18 - 19









# 316 352 600 001



<b>X</b>	 HM 10 x 45 Cl 8.8	4
	 L10 / 27 x 3	4
	 CS 10	4
	 25 / 18 / 10	2





<b>Y</b>	 HM 10 x 45 Cl 8.8	2
	 CS 10	2

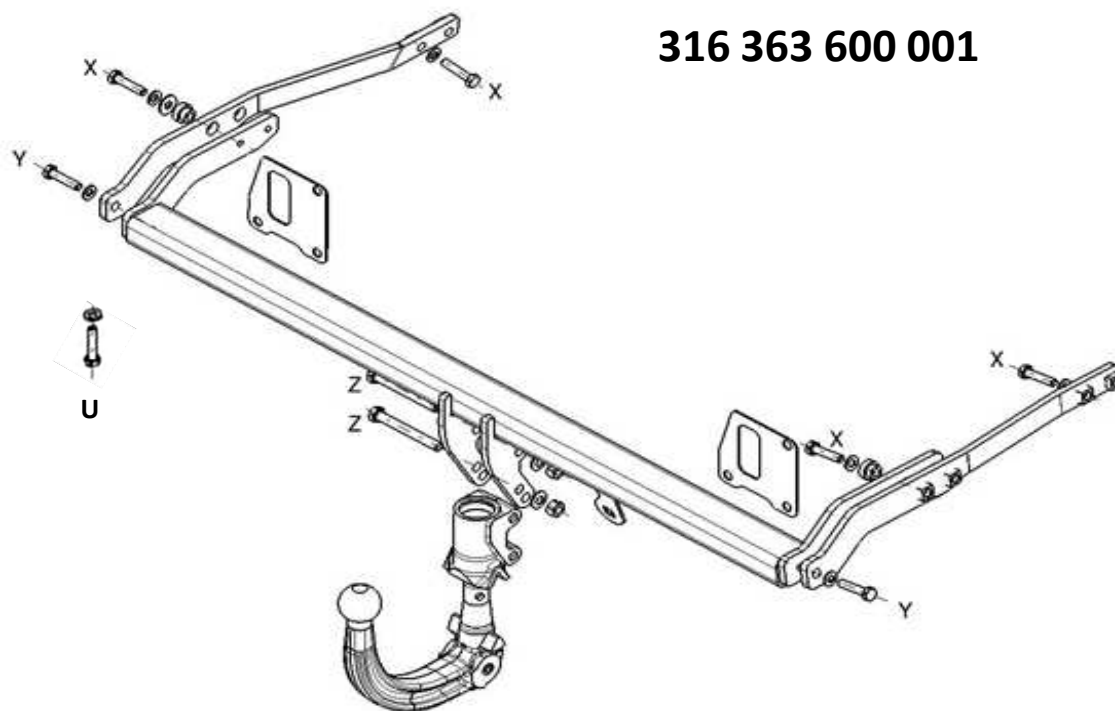

<b>Z</b>	 HM 12 x 60 Cl 8.8	2
	 M12 Cl8	2
	 CS 12	2
	 L 12 / 27	1





<b>U</b>	 HM 8 x 30 Cl 8.8	1	
	 CS 8	1	



316 363 600 001



<b>X</b>	 HM 10 x 45 Cl 8.8	4
	 L10 / 27 x 3	4
	 CS 10	4
	 25 / 18 / 10	2

<b>Y</b>	 HM 10 x 45 Cl 8.8	2
	 CS 10	2

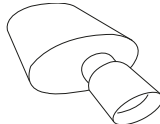
<b>Z</b>	 HM 12 x 100 Cl 10.9	2
	 M12 Cl10	2
	 CS 12	2
	 L 12 / 27	1

<b>U</b>	 HM 8 x 30 Cl 8.8		1
	 CS 8		1

01

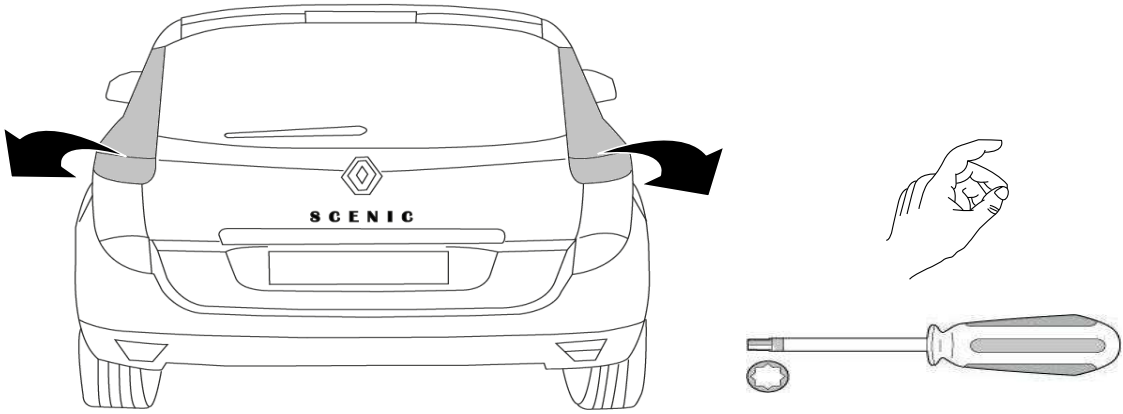

02

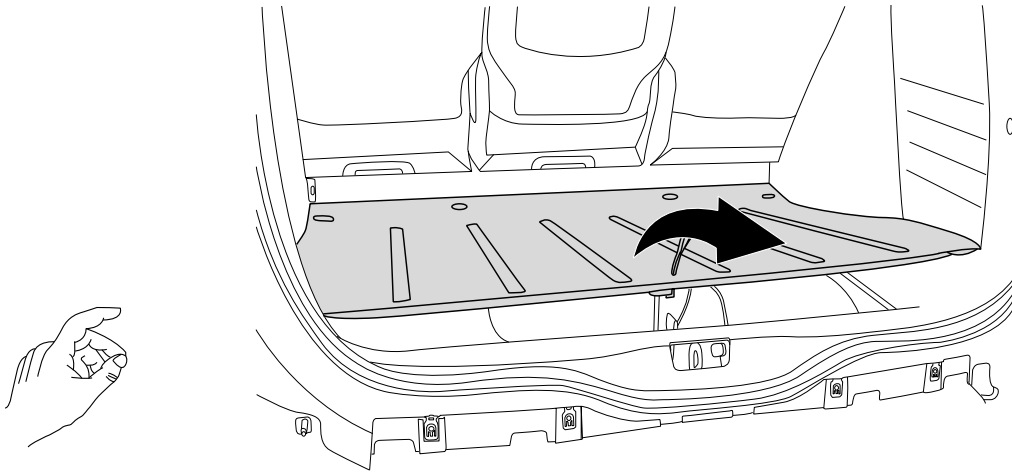

03

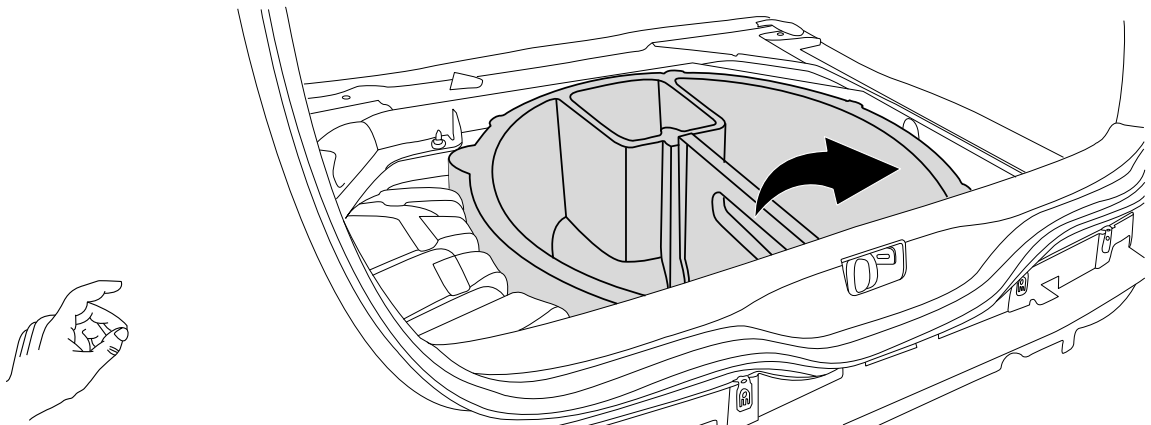

04

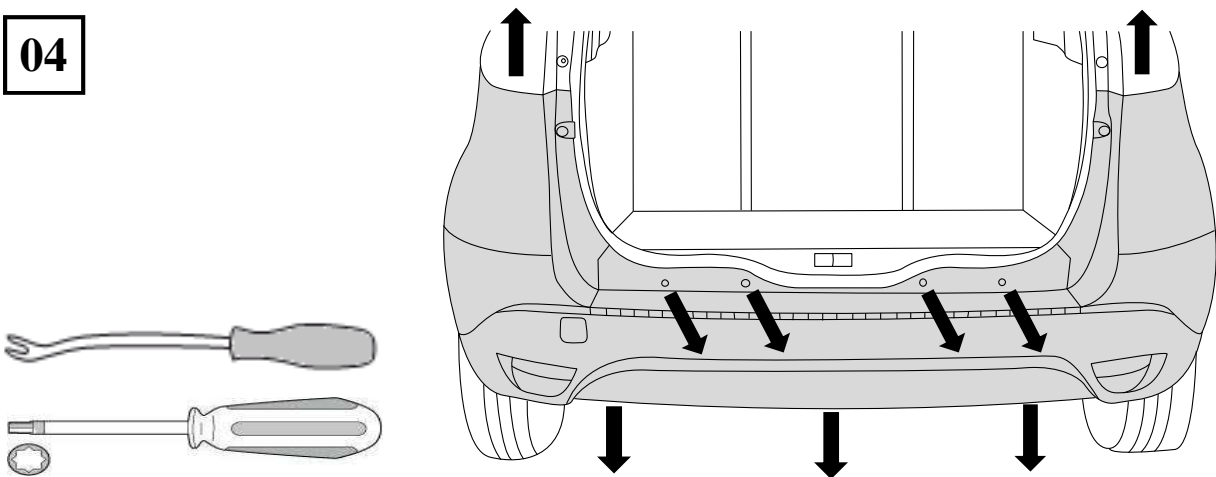

05

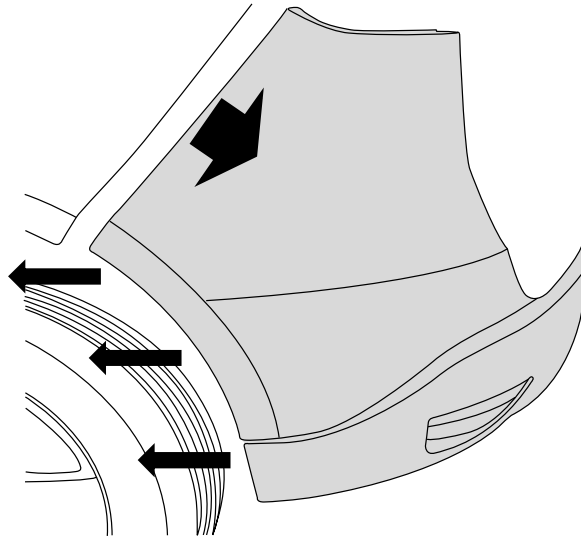
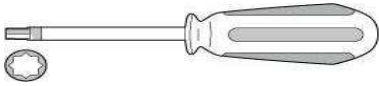

06

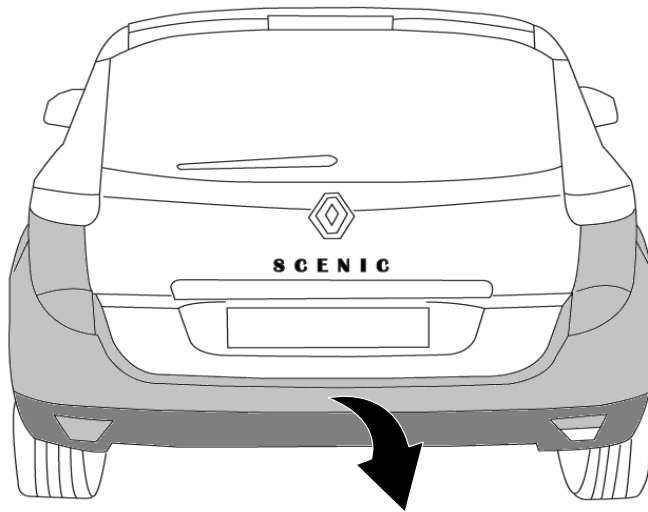
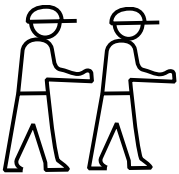

07

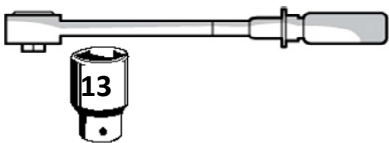
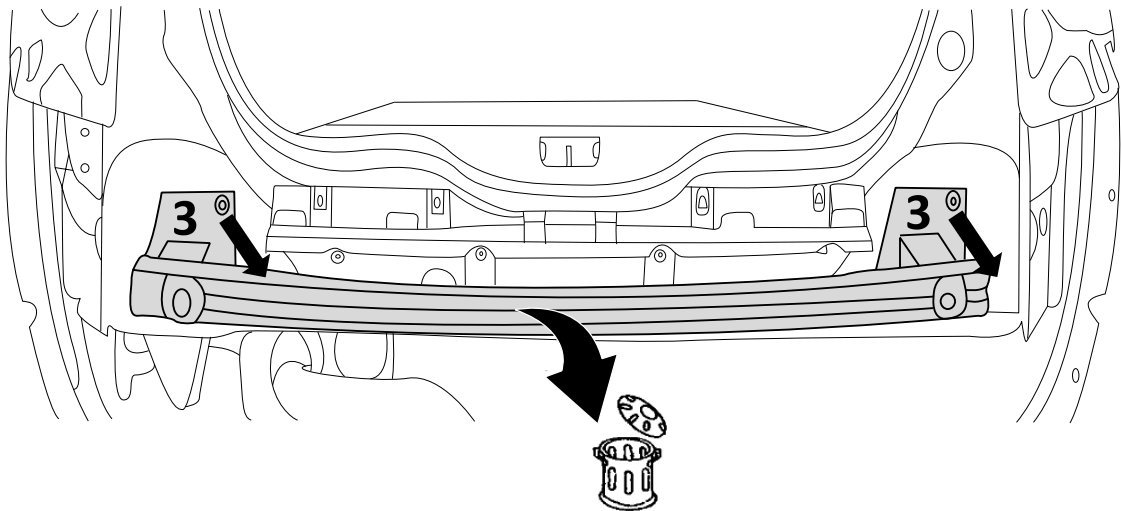

08

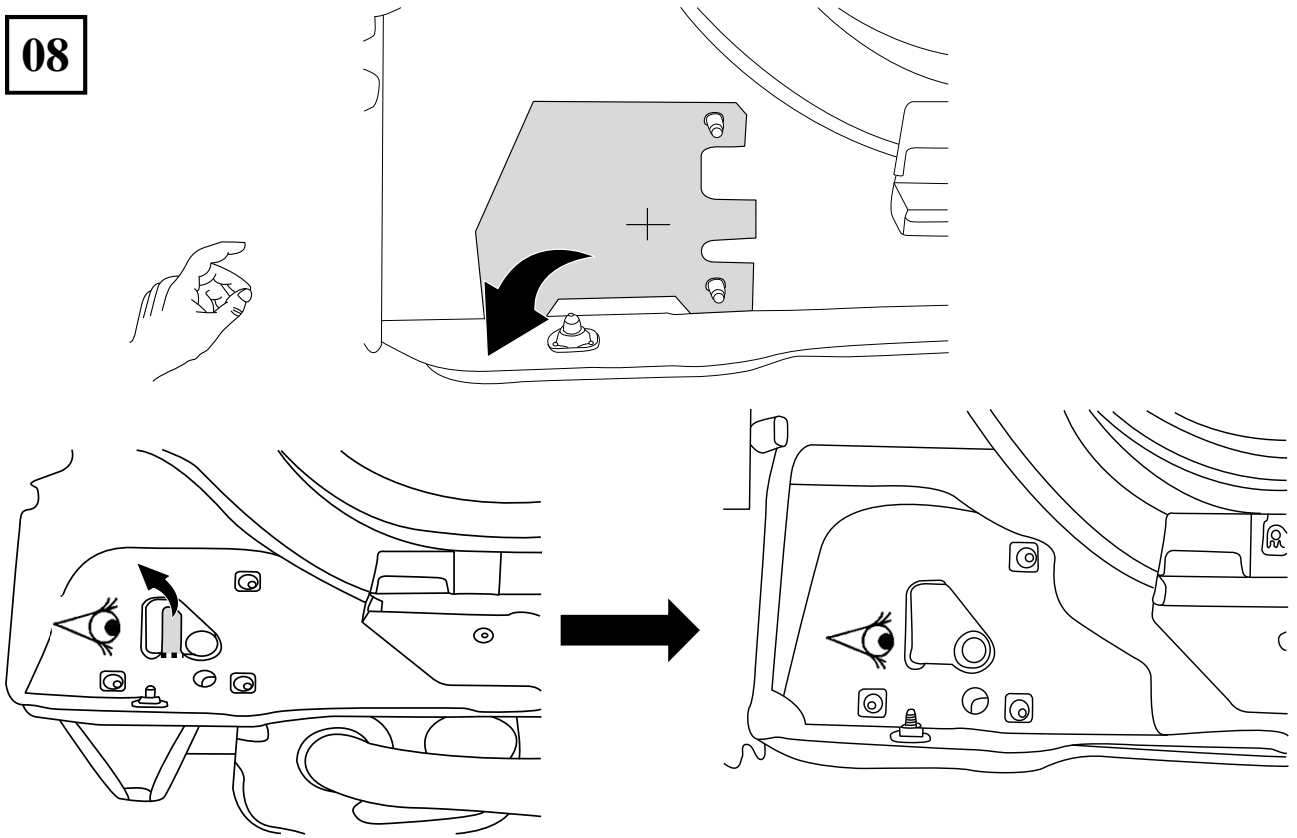

09

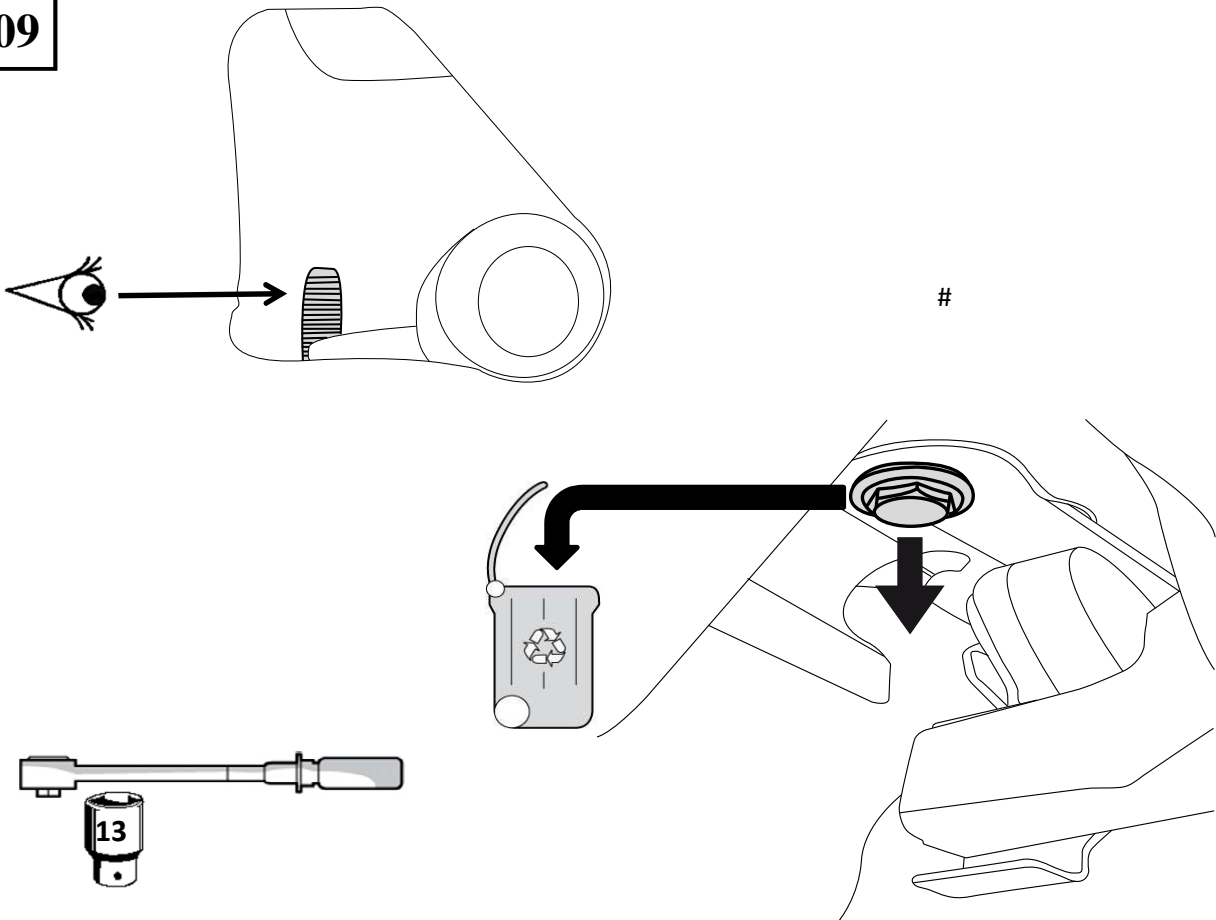

10

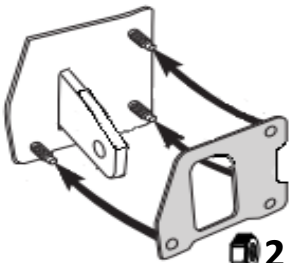
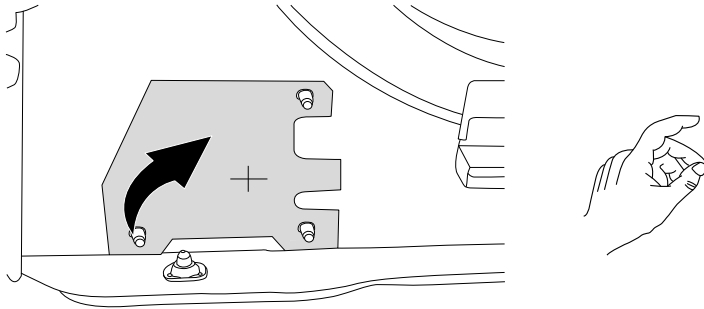

2 X 3

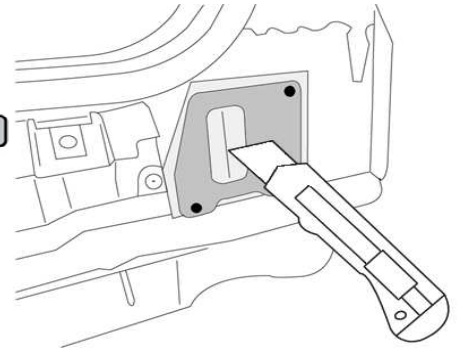
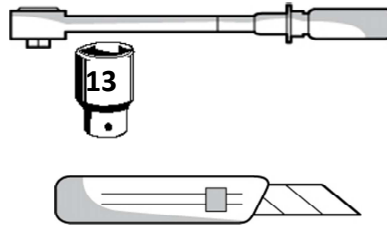
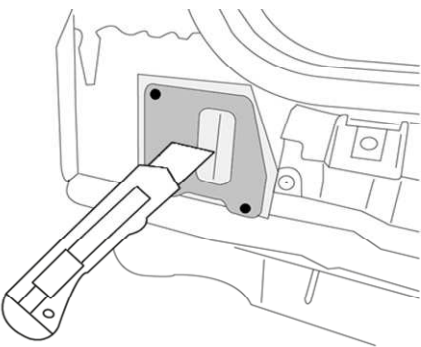
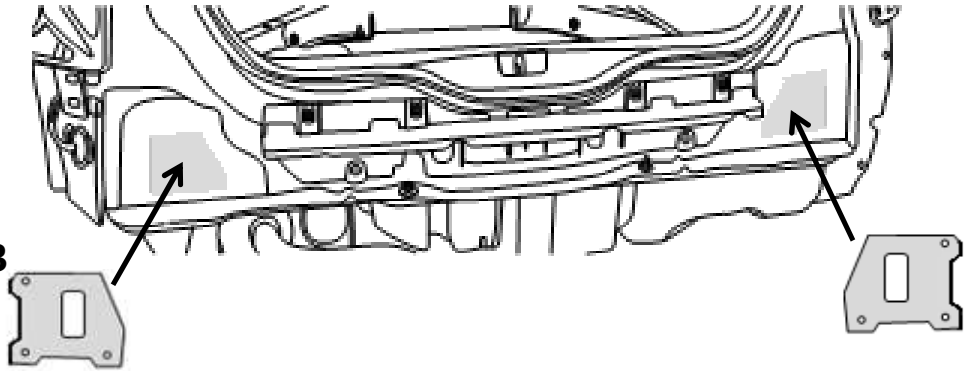

11

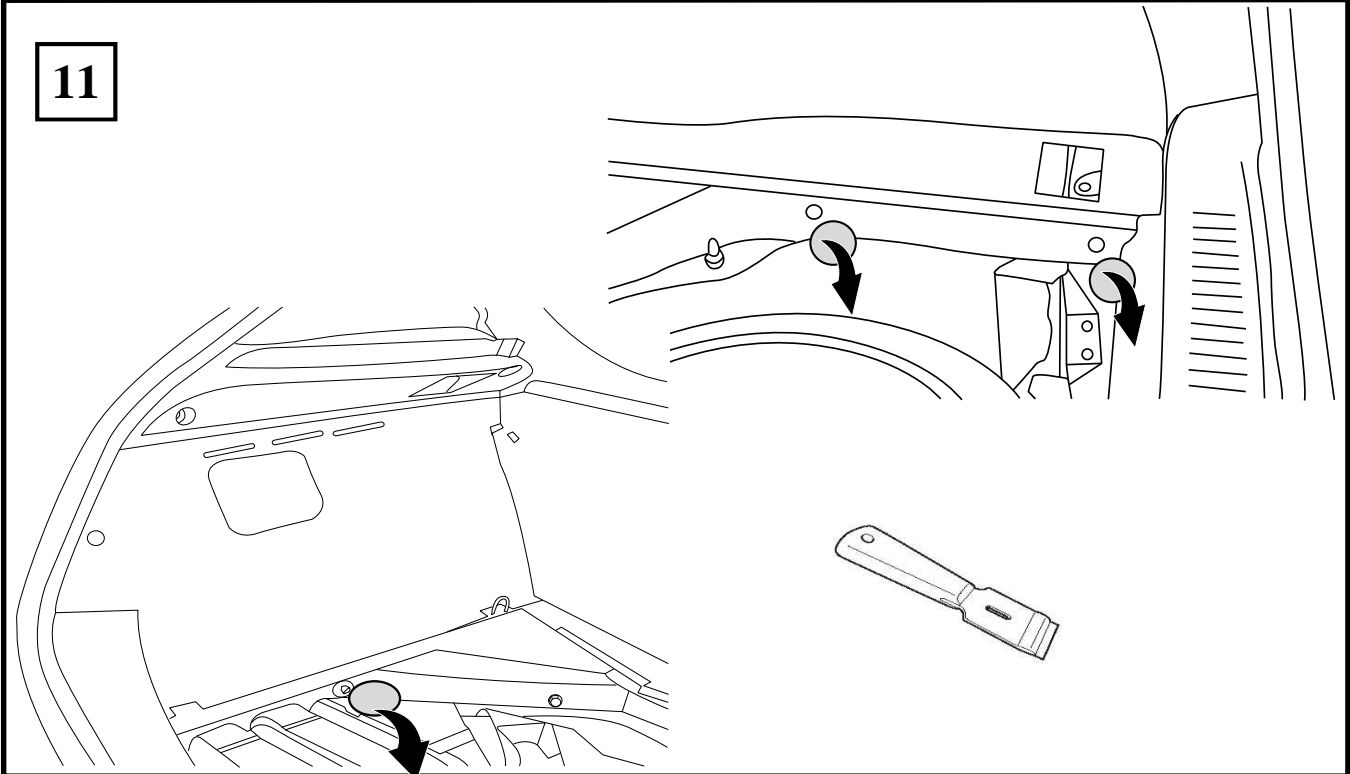



12

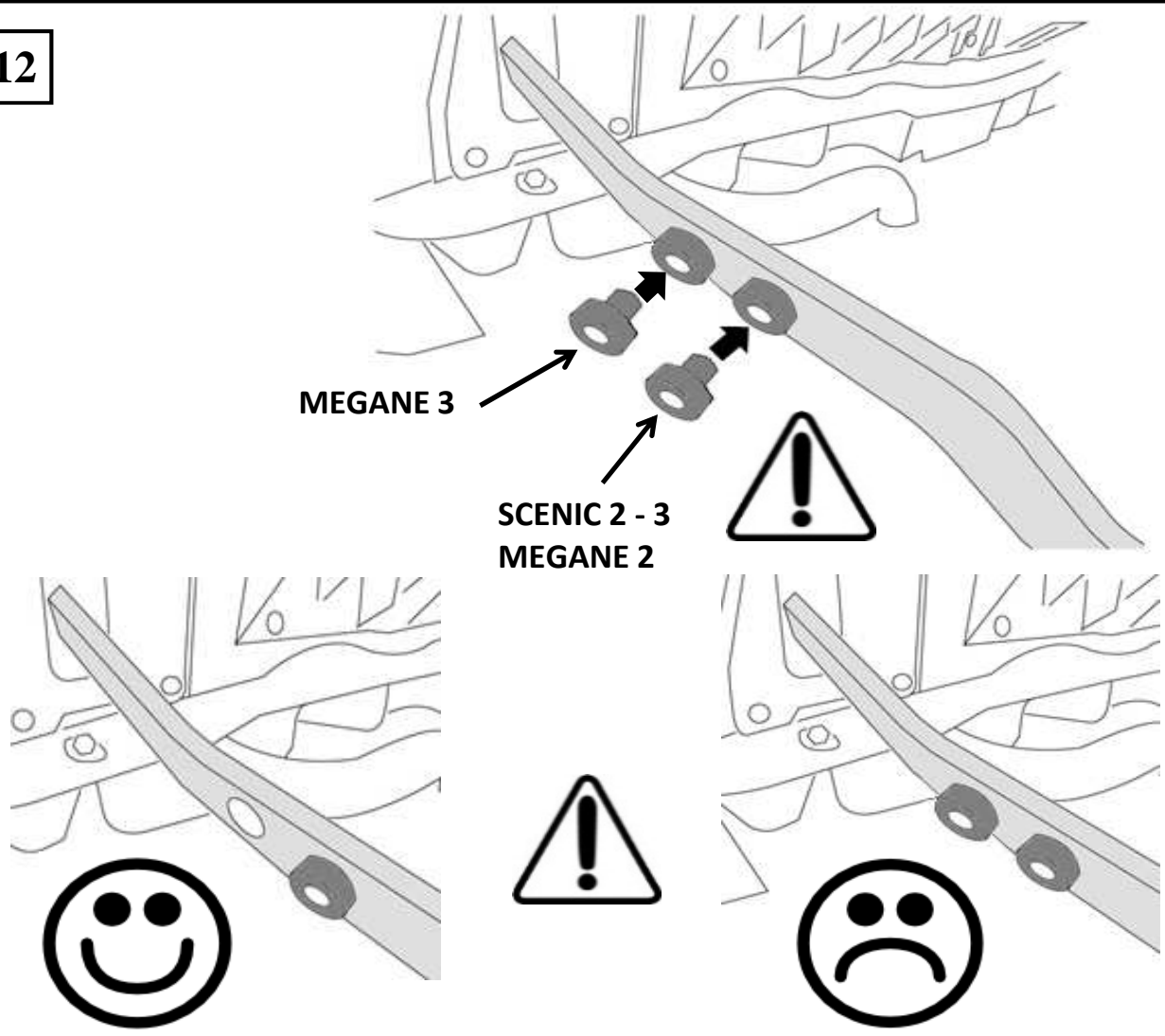

13

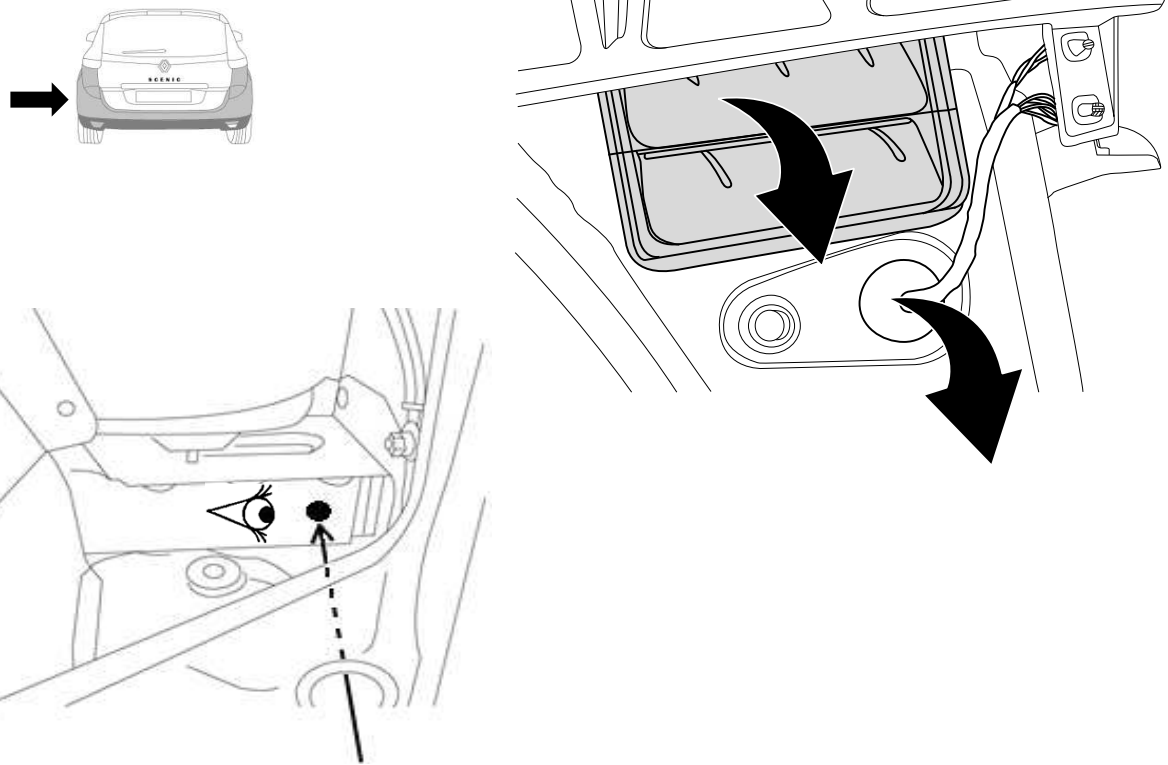

14

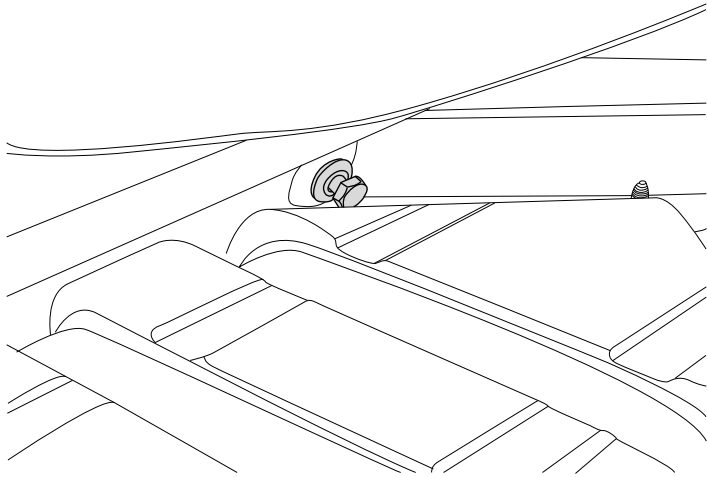

15

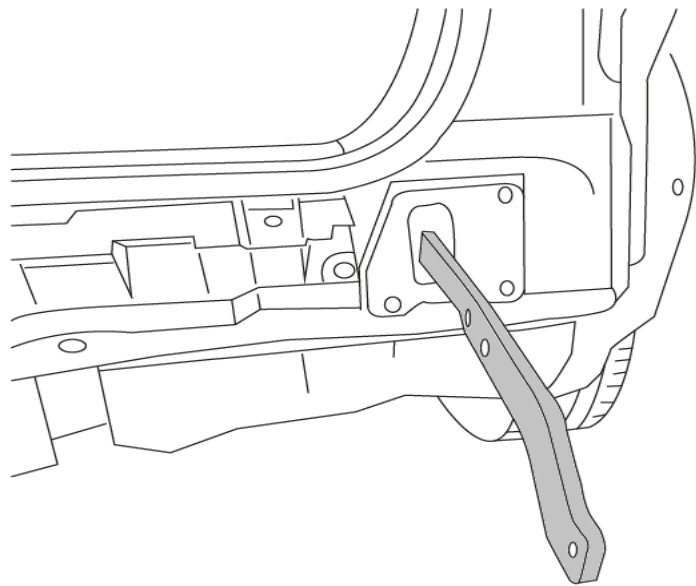

16

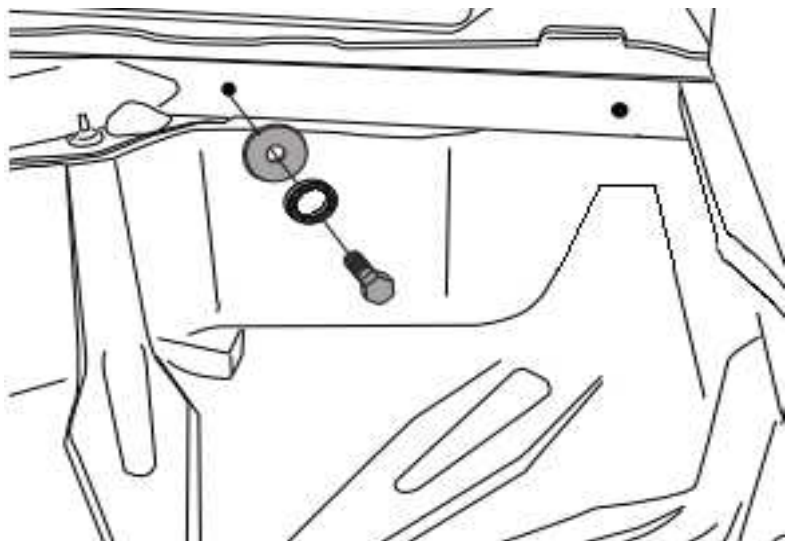

17

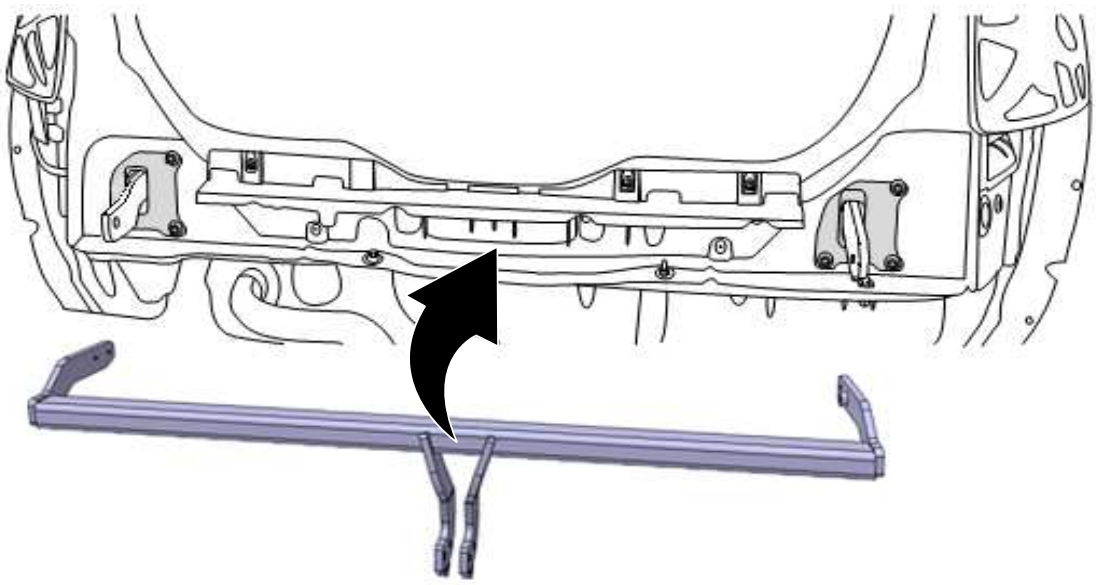

18

MEGANE 3

SCENIC 2 - 3  
MEGANE 2



X 1

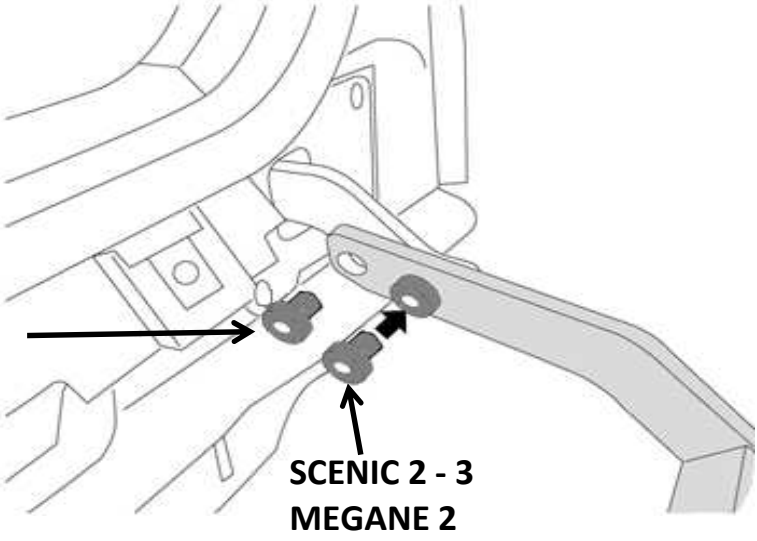

19

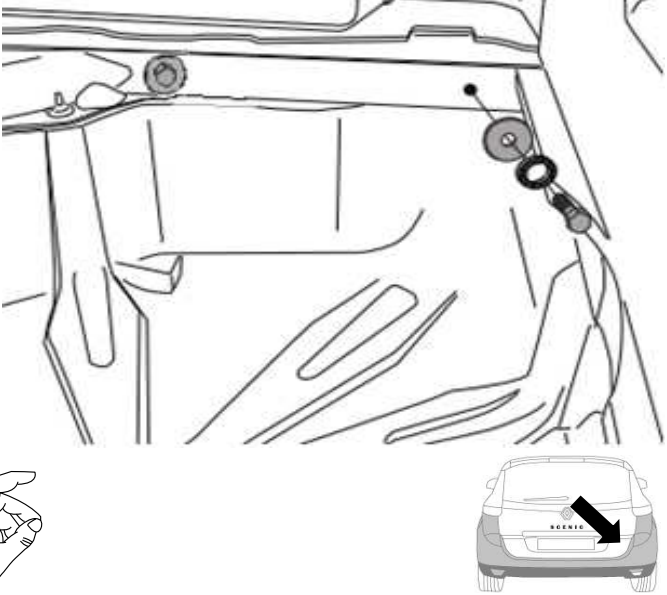
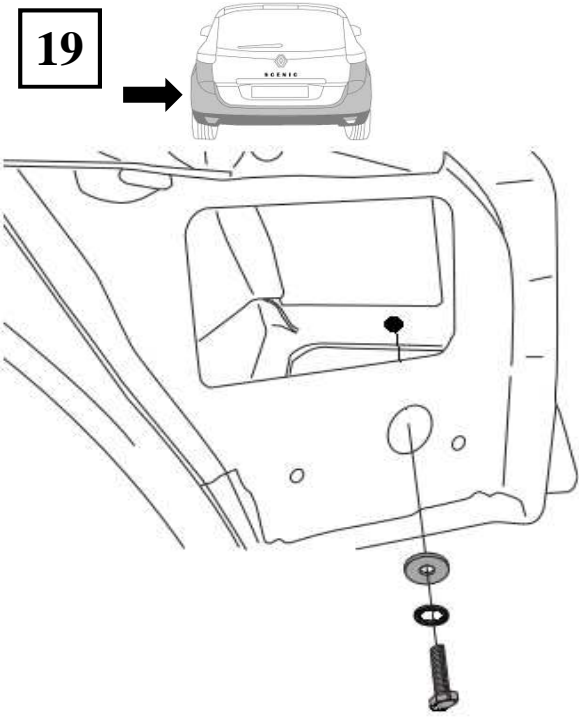

20

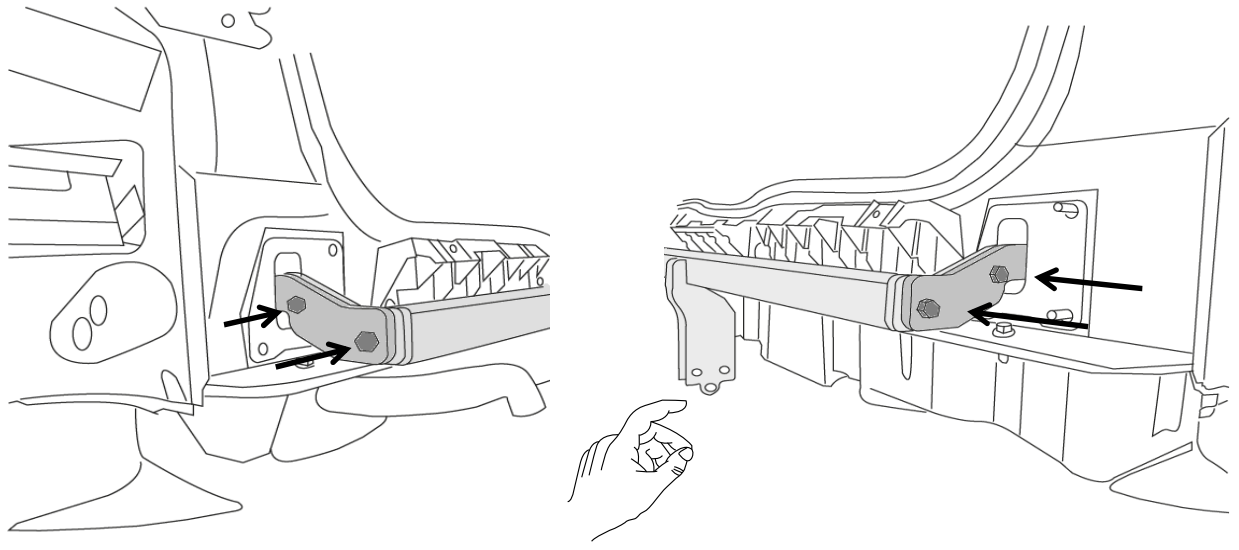

21

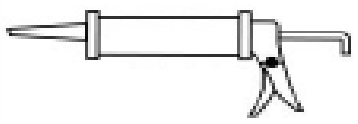
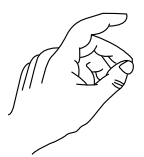
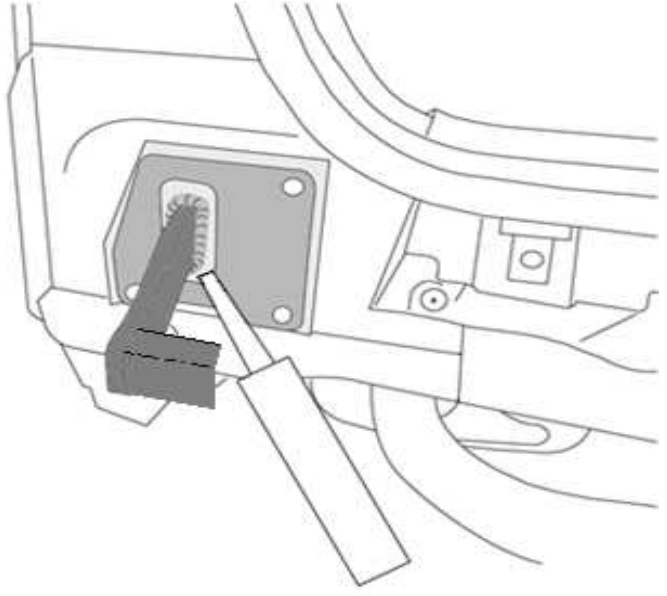
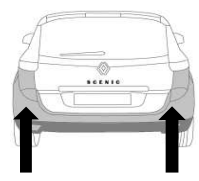

22

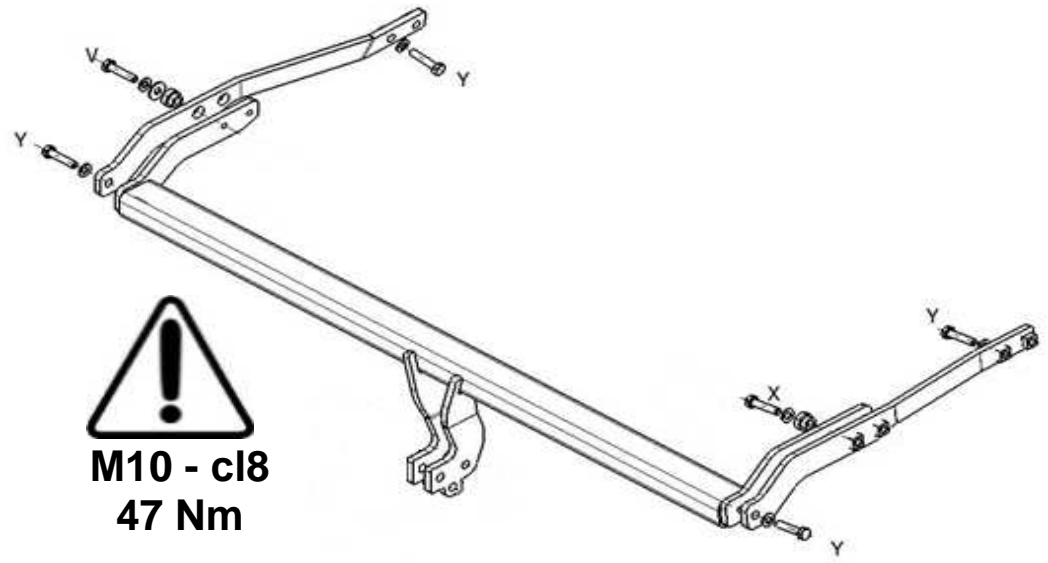

M10 - cl8  
47 Nm

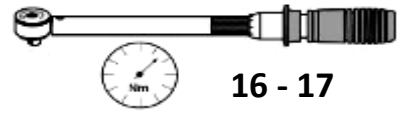

16 - 17

23



M8 - cl8  
23 Nm

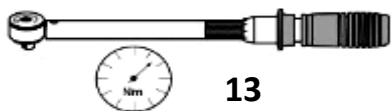
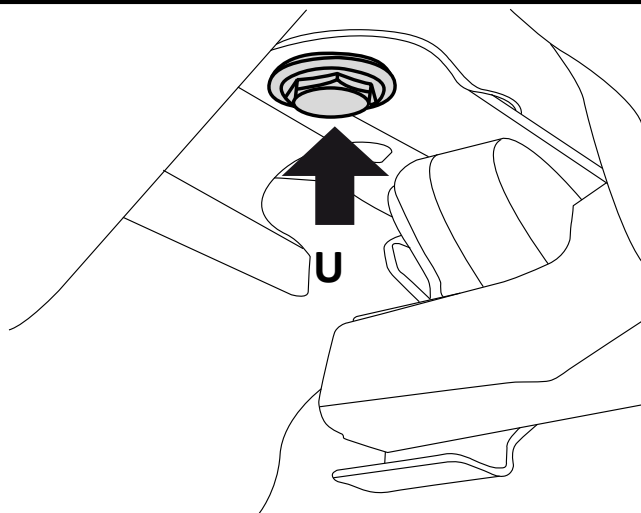

24

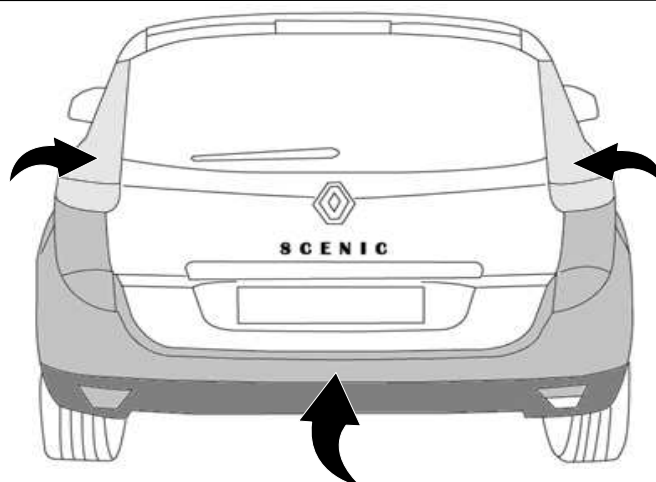
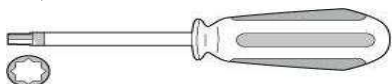

25



M12 - cl8  
81 Nm

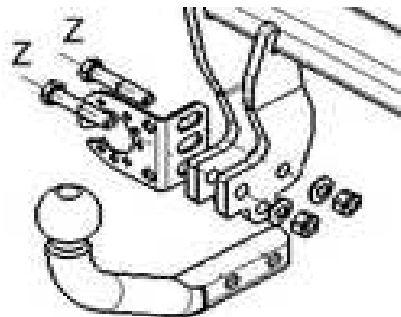
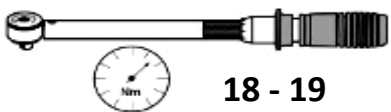

M12 - cl10  
114 Nm

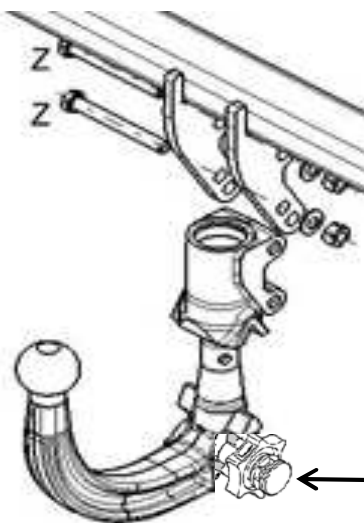
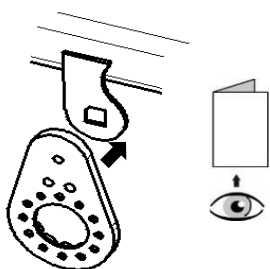

Dispositivo di traino tipo : **316352 - 316363**  
Per autoveicolo : **Renault Mégane 2, Mégane 3 Scenic 2, Scenic 3**  
Tipo funzionale : **BM - CM - SM - JM**  
**BZ - DZ - JZ..O**

**WESTFALIA**

*Monoflex*



Classe e tipo di attacco : **A50-X**  
Omologazione : **e24\*55R\*01 0322 (316352) - e24\*55R\*01 0321 (316363)**  
Valore D : **8,67 kN**  
Carico verticale max. S : **75 kg**  
Massa rimorchiabile : vedi carta di circolazione dell'autoveicolo

In base alla Direttiva europea 94/20, la massa massima rimorchiabile del dispositivo di traino è determinata dal valore di prova "D" così definito :

$$D = (T \times C) / (T + C) \times 0,00981 = 8,67 \text{ kN}$$

dove : T = Massa complessiva max. della motrice (in kg) e C = Massa rimorchiabile max. della motrice (in kg)

**DICHIARAZIONE DI CORRETTO MONTAGGIO :**

la sottoscritta Ditta dichiara che il dispositivo di traino tipo \_\_\_\_\_ è stato installato a regola d'arte, nel rispetto dei punti d'attacco e delle prescrizioni fornite dalla Casa costruttrice

sul veicolo **Mégane 2 / Scenic 2 / Mégane 3 / Scenic 3**

targato \_\_\_\_\_

li \_\_\_\_\_

timbro et firma

Si dichiara inoltre di aver informato l'utente del veicolo sull'USO e MANUTENZIONE del dispositivo stesso.



[holownicze.pl](http://holownicze.pl)